



# **SnapStream Series**



**Technical and  
Installation Manual**



## INTRODUCTION

The SnapStream system is a digitally controlled weighing and diagnostic scale as well as displaying functionality. The entire system was designed around the 802.15.4 Zigbee protocol for reliable and accurate weight and data transmission and can be used with any 200 Digital Weight Indicator (DWI).

The SnapStream system can be configured with 1-16 load cells. The SnapStream junction box for truck scales can fit 2 to four 4-cell analog boards and the Single board junction box is the exact size of the current floor hugger junction box allowing easy transition from wired to wireless for up to 4 floor huggers. These junction boxes perform the analog to digital weight conversion for each load cell and can transmit data wirelessly to any 200 series DWI where the weight data can be displayed or sent wirelessly to any scoreboard or local remote Cardinal has to offer. The communications module can also be used to interface wirelessly from the DWI to a computer or printer using USB, RS232 or Ethernet.

The SMARTCAL® feature allows quick calibration with no manual adjustments while the diagnostic software identifies real and potential system problems before they interrupt your weighing operations.

The SnapStream System indicator, snap junction box and snap radio are housed in an NEMA 4X/IP66 rated enclosure.

This manual describes the installation, setup, and calibration of the SnapStream System. Please make sure that you read this manual in its entirety before beginning the installation or attempting to operate the SnapStream System. Also, make certain that you pay attention to the warnings that appear in this manual. Failure to read and follow these instructions and warnings may result in damage to the scale and/or bodily injury. Please keep this manual handy for future reference.

## COPYRIGHT

All rights reserved. Reproduction or use, without expressed written permission, of editorial or pictorial content, in any manner, is prohibited. No patent liability is assumed with respect to the use of the information contained herein.

## **DISCLAIMER**

While every precaution has been taken in the preparation of this manual, the Seller assumes no responsibility for errors or omissions. Neither is any liability assumed for damages resulting from use of the information contained herein. All instructions and diagrams have been checked for accuracy and ease of application; however, success and safety in working with tools depend to a great extent upon the individual accuracy, skill and caution. For this reason the Seller is not able to guarantee the result of any procedure contained herein. Nor can they assume responsibility for any damage to property or injury to persons occasioned from the procedures. Persons engaging the procedures do so entirely at their own risk.

## **FCC COMPLIANCE STATEMENT**

This equipment generates uses and can radiate radio frequency and if not installed and used in accordance with the instruction manual, may cause interference to radio communications. It has been tested and found to comply with the limits for a Class A computing device pursuant to Subpart J of Part 15 of FCC rules, which are designed to provide reasonable protection against such interference when operated in a commercial environment. Operation of this equipment in a residential area may cause interference in which case the user will be responsible to take whatever measures necessary to correct the interference.

You may find the booklet "How to Identify and Resolve Radio TV Interference Problems" prepared by the Federal Communications Commission helpful. It is available from the U.S. Government Printing Office, Washington, D.C. 20402. Order stock no. 001-000-00315-4.

## PROPER DISPOSAL

When this device reaches the end of its useful life, it must be properly disposed of. It must not be disposed of as unsorted municipal waste. Within the European Union, this device should be returned to the distributor from where it was purchased for proper disposal. This is in accordance with EU Directive 2002/96/EC. Within North America, the device should be disposed of in accordance with the local laws regarding the disposal of waste electrical and electronic equipment.

It is everyone's responsibility to help maintain the environment and to reduce the effects of hazardous substances contained in electrical and electronic equipment on human health. Please do your part by making certain that this device is properly disposed of. The symbol shown to the right indicates that this device must not be disposed of in unsorted municipal waste programs.

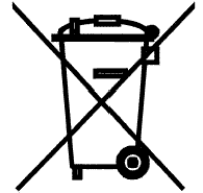

### PRECAUTIONS

Before using this indicator, read this manual and pay special attention to all "WARNING" symbols:



**IMPORTANT**



**ELECTRICAL  
WARNING**



**STATIC  
SENSITIVE**



## TABLE OF CONTENTS

<b>SPECIFICATIONS</b> .....	<b>2</b>
SNAP-RF (8300-D027-0A) .....	3
SNAP-RADIO JUNCTION BOX (8300-C060-0A) .....	5
SNAP-4LF (8300-D059-0A) .....	7
SNAP-4S (8300-C012-0A) .....	9
SNAP-4R .....	11
SNAP-4 .....	13
SNAP-8S (8300-D026-0A) .....	15
SNAP-8 .....	17
SNAP-12 .....	19
SNAP-16 .....	21
SNAP 12S (8300-D026-1A) .....	23
SNAP-3x4 / SNAP-10 .....	25
SNAP-16S (8300-D026-2A) .....	27
SNAP-4X4 .....	29
2XX-SNAP (8200-C568-0A) .....	31
SNAP-COM (8300-C016-0A) .....	33
SNAP-COMIP (8300-C016-1A) .....	35
<b>PRECAUTIONS</b> .....	<b>37</b>
Static Electricity .....	37
<b>INSTALLATION</b> .....	<b>39</b>
Site Preparation Requirements .....	39
Environmental .....	39
Electrical Power .....	39
Transient Suppression .....	39
<b>WIRING THE SNAP-4R</b> .....	<b>41</b>
Re-Installing the SNAP-4R Cover .....	44
<b>WIRING THE SNAP-4</b> .....	<b>45</b>
Re-Installing the SNAP-4S Cover .....	46
Connecting the SNAP-4 to the SNAP-RF .....	46

SnapStream Series

WIRING THE SNAP-4LF.....	47
Connecting SNAP-4LF to SNAP-RADIO JUNCTION BOX.....	48
Re-Installing the SNAP-RADIO JUNCTION BOX Cover .....	48
WIRING THE SNAP-12.....	49
WIRING THE SNAP-8, -3X4/SNAP-10, SNAP-4X4.....	51
WIRING THE SNAP-16.....	53
SNAP-4R SETUP .....	55
USING 205, 210 OR 215.....	55
MAKING LOAD CELL ADJUSTMENTS USING 205, 210 OR 215.....	57
USING 225 .....	59
SNAP-4, -8, -12, -3X4 (-10), -16, -4X4, SETUP .....	69
USING 205, 210 OR 215.....	69
MAKING LOAD CELL ADJUSTMENTS USING 205, 210 OR 215.....	71
USING 225 .....	73
2XX-SNAP (8200-C568-0A) OPTION CARD.....	83
2XX SNAP Indicator Installation .....	83
Antenna Cable Installation.....	85
2XX-SNAP Address.....	85
2XX-SNAP Radio Speed and Channel Selection .....	86
2XX-SNAP Diagnostic LED's.....	88
Re-Installing The Rear Panel.....	88
2XX-SNAP LOCAL/REMOTE .....	89
USING A 205, 210 OR 215.....	89
USING A 225.....	90
2XX-SNAP SCOREBOARD INSTALLATION .....	91
2XX-SNAP SCOREBOARD SETUP .....	93
USING A 205, 210 OR 215.....	93
USING A 225.....	95
SNAP-COM (8300-C016-0A) / SNAP-COMIP (8300-C016-01) .....	97
SNAP-COM LED and Jumper Description.....	98



SNAP-COM SETUP .....	101
USING 205, 210, 215.....	101
USING A 225 .....	103
SNAP-COM LOCAL/REMOTE .....	105
USING 205, 210, OR 215.....	105
USING 225.....	107
SNAP-COM SCOREBOARD INSTALLATION .....	109
HYPERTERMINAL COMMANDS.....	111
SNAP-COM PC SETUP .....	113
DIAGNOSTICS .....	115
205 .....	115
210/215 .....	115
Master Clear 205, 210/215.....	116
225 .....	117
Master Clear 225.....	118
TROUBLESHOOTING.....	119
Guide to Optimum Signal Strength.....	119
Antenna Placement.....	119
Avoid Obstacles and Interference .....	119
Cordless Phones.....	120
8300-D001-0A LED and Jumper Description .....	123
8300-C002-2A LED and Jumper Description .....	125





# SPECIFICATIONS

## SNAP-RF (8300-D027-0A)

### **SNAP-RF [8300-D027-0A]**

- RADIO AND ANTENNA FOR WIRELESS OUTPUT
- POWER SUPPLY PANEL FOR 120VAC TO DC CONVERTER

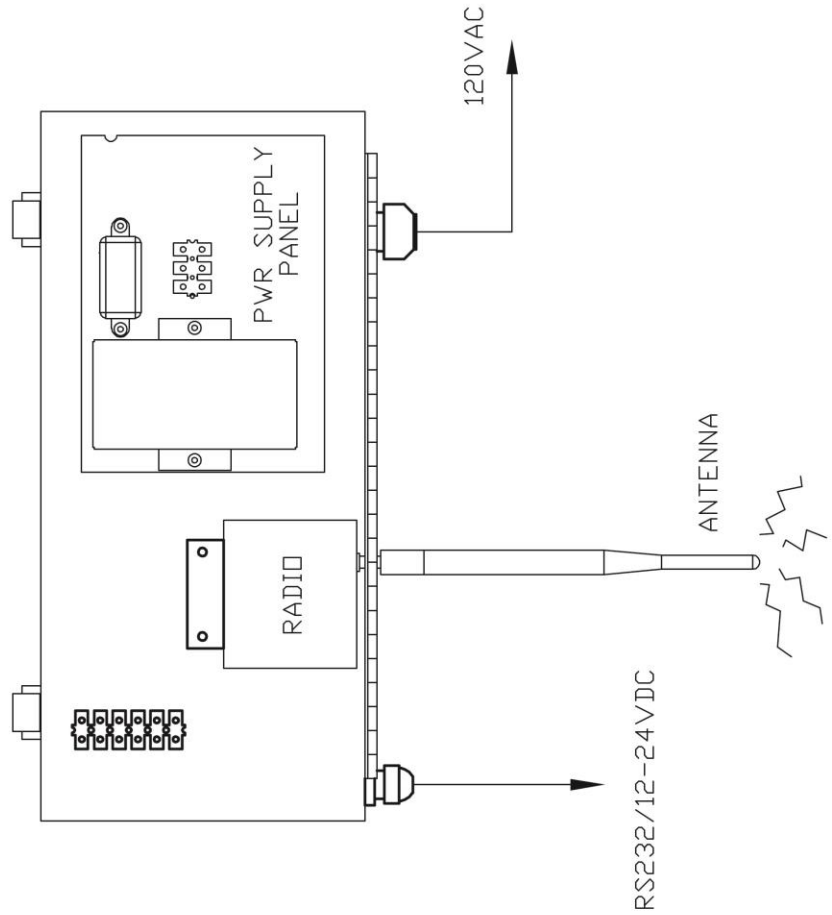

**SNAP-RF (8300-D027-0A)**

Power Requirements:	12-24 VDC at 1.0A Max.
Temperature Range: (Compensated)	-13 to 104 °F (-25 to +40 °C)
Hardware:	Junction-Box Style Scalebox with Radio and Antenna for wireless output Power Supply for 120VAC to DC Converter
SNAP-RF Connections:	RS232/12-24VDC, Antenna, 120VAC for Power Supply Panel
Transmission Distance	Up to 1 mile Line Of Sight (LOS), Wireless Up to 30 feet, RS232

# SNAP-RADIO JUNCTION BOX (8300-C060-0A)

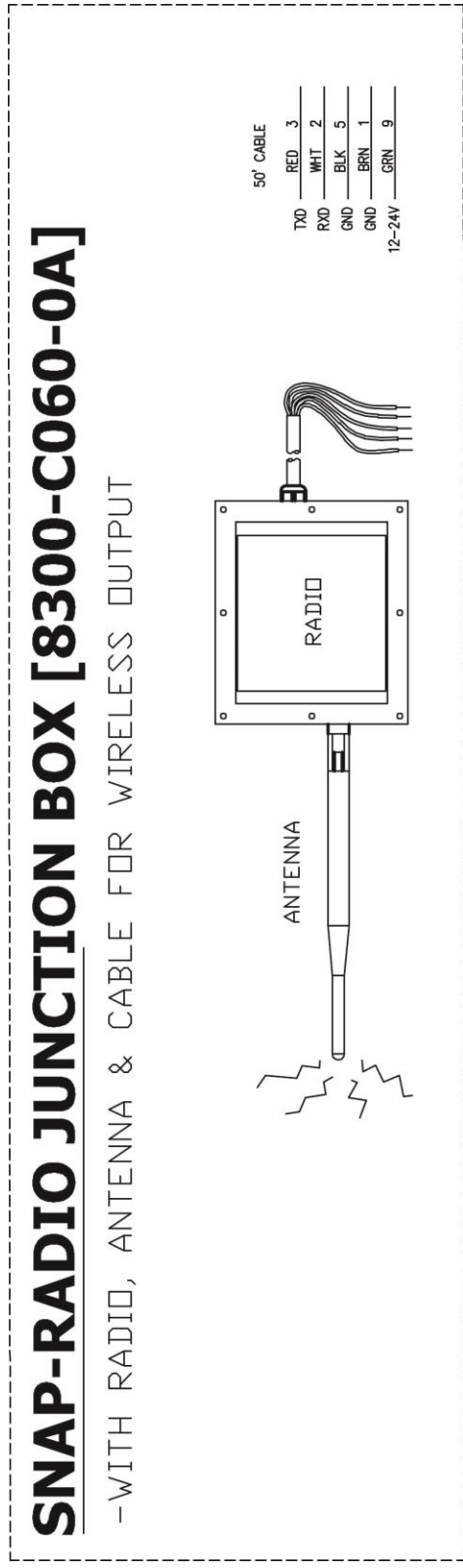

**SNAP-RADIO JUNCTION BOX (8300-C060-0A)**

Power Requirements:	12-24 VDC at 1.0A Max.
Temperature Range: (Compensated)	-13 to 104 °F (-25 to +40 °C)
Hardware:	Small Junction-Box with Radio and Antenna for wireless output and 50' of 12-24VDC and RS232 Communications Cable
SNAP-Radio Junction Box Connections:	RS232/12-24VDC, Antenna
Transmission Distance	Up to 1 mile Line Of Sight (LOS), Wireless Up to 30 feet, RS232

# SNAP-4LF (8300-D059-0A)

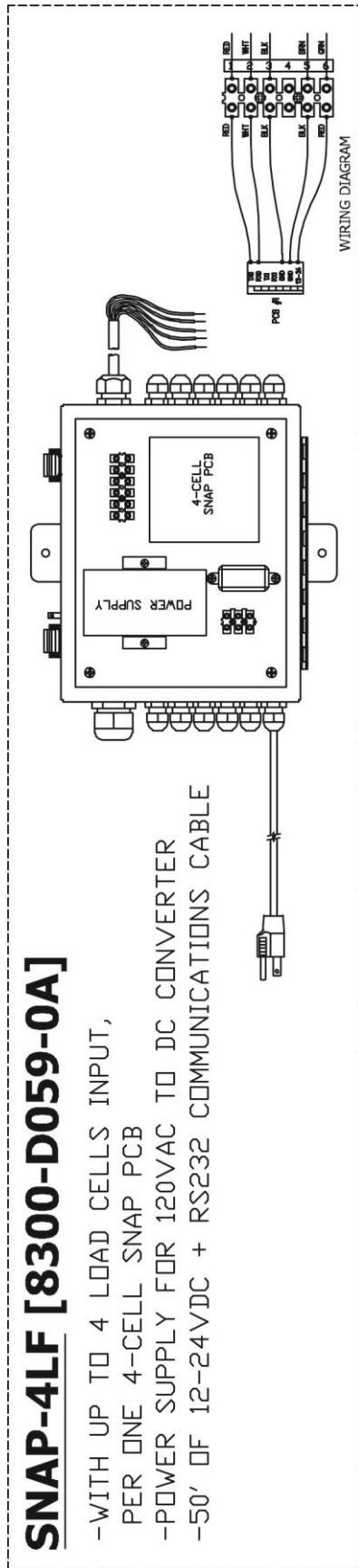



**SNAP-4LF (8300-D059-0A)**

Power Requirements:	100 to 240 VAC (50/60 Hz) at 0.4A Max.
Temperature Range: (Compensated)	-13 to 104 °F (-25 to +40 °C)
Hardware:	Universal Section Seal Trim Box with 1 (4-Cell SNAP PCB), Power Supply for 120VAC to DC Converter and 50' of 12-24VDC and RS232 Communications Cable
SNAP-4LF Connections:	4 Load Cell Inputs, Power (120VAC)
Sample Rate:	1 to 20 samples per second, selectable
Load Cells:	(4) 350 ohm strain gauge load cells
Excitation Voltage:	12VDC
Sensitivity:	
NON-COMMERCIAL	0.15 uV/e
NTEP	0.3uV/e (Class III/IIIL)
CANADA	0.3uV/e (Class III/IIHHD)
Scale Divisions:	
NON-COMMERCIAL	100 to 240,000
NTEP	100 to 100,000 (Class III/IIIL)
CANADA	100 to 100,000 (Class III/IIHHD)
Internal Resolution:	1 part in 16,777,216
Transmission Distance	Up to 1 mile Line Of Sight (LOS), Wireless Up to 30 feet, RS232

**SNAP-4S (8300-C012-0A)**

**SNAP-4S [8300-C012-0A]**

-WITH UP TO 4 LOAD CELLS INPUT, PER ONE 4-CELL SNAP PCB  
-50' OF 12-24VDC + RS232 COMMUNICATIONS CABLE

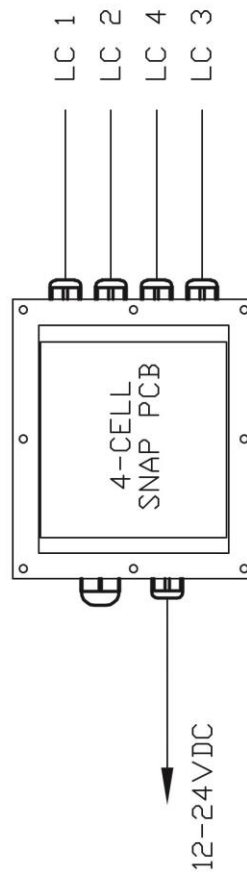

**SNAP-4S (8300-C012-0A)**

Power Requirements:	12-24 VDC at 1.0A Max.
Temperature Range: (Compensated)	-13 to 104 °F (-25 to +40 °C)
Hardware:	Small Junction-Box with 1 (4-Cell SNAP PCB) and 50' of 12-24VDC and RS232 Communications Cable
SNAP-4S Connections:	4 Load Cell Inputs, Power (12-24VDC)
Sample Rate:	1 to 20 samples per second, selectable
Load Cells:	(4) 350 ohm strain gauge load cells
Excitation Voltage:	12VDC
Sensitivity:	
NON-COMMERCIAL	0.15 uV/e
NTEP	0.3uV/e (Class III/IIIL)
CANADA	0.3uV/e (Class III/IIIRD)
Scale Divisions:	
NON-COMMERCIAL	100 to 240,000
NTEP	100 to 100,000 (Class III/IIIL)
CANADA	100 to 100,000 (Class III/IIIRD)
Internal Resolution:	1 part in 16,777,216
Transmission Distance	Up to 1 mile Line Of Sight (LOS), Wireless Up to 30 feet, RS232

# SNAP-4R



**SNAP-4R**

Power Requirements:	12-24 VDC at 1.0A Max.
Temperature Range: (Compensated)	-13 to 104 °F (-25 to +40 °C)
Hardware:	1 SNAP-4S (4-Cell SNAP PCB) with Radio, Antenna and Antenna Cable
SNAP-4R Connections:	4 Load Cell Inputs, Power (12-24VDC), Antenna Cable
Sample Rate:	1 to 20 samples per second, selectable
Load Cells:	(4) 350 ohm strain gauge load cells
Excitation Voltage:	12VDC
Sensitivity:	
NON-COMMERCIAL	0.15 uV/e
NTEP	0.3uV/e (Class III/IIIL)
CANADA	0.3uV/e (Class III/IIIRD)
Scale Divisions:	
NON-COMMERCIAL	100 to 240,000
NTEP	100 to 100,000 (Class III/IIIL)
CANADA	100 to 100,000 (Class III/IIIRD)
Internal Resolution:	1 part in 16,777,216
Transmission Distance	Up to 1 mile Line Of Sight (LOS), Wireless

# SNAP-4

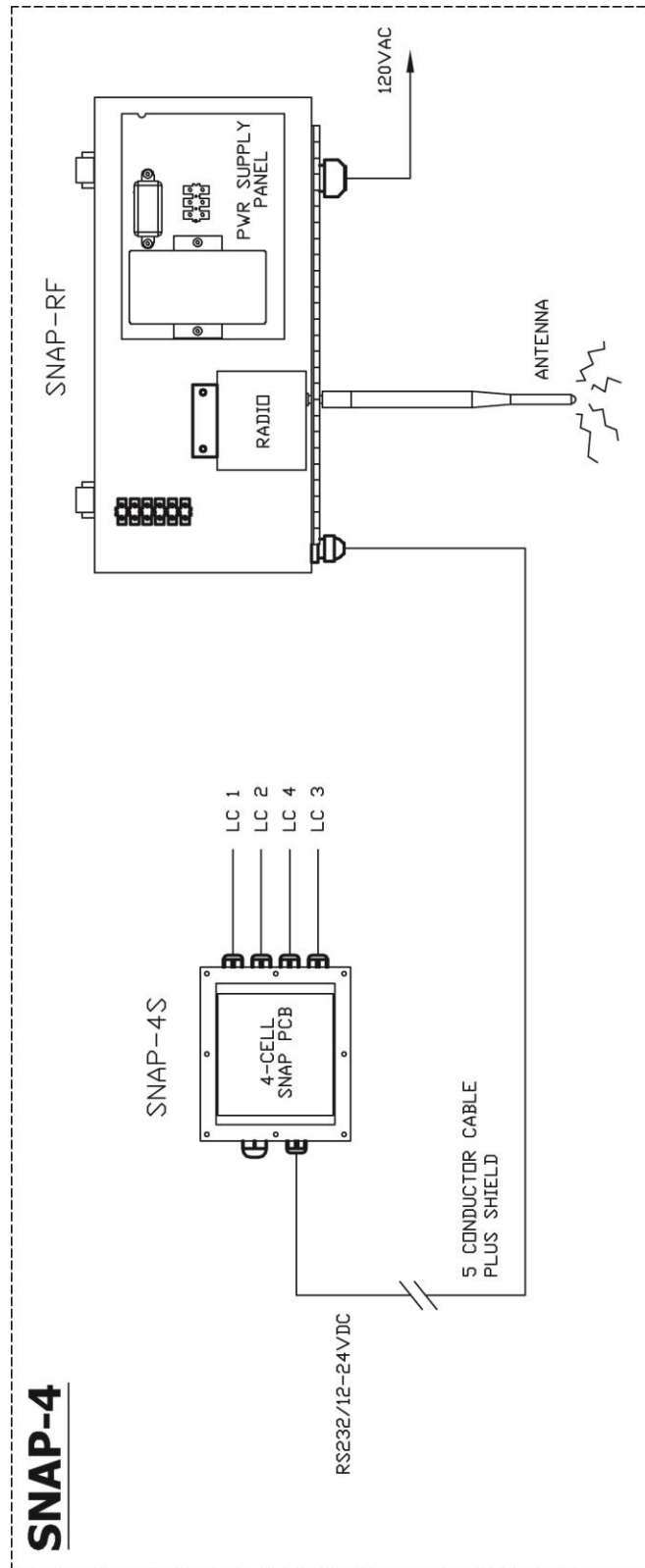

**SNAP-4**

Power Requirements:	12-24 VDC at 1.0A Max.
Temperature Range: (Compensated)	-13 to 104 °F (-25 to +40 °C)
Hardware:	1 SNAP-4S and 1 SNAP-RF
SNAP-4S	4 Load Cell Inputs,
Connections:	RS232/12-24VDC to SNAP-RF
SNAP-RF	RS232/12-24VDC from SNAP-4S,
Connections:	Antenna, 120VAC for Power Supply Panel
Sample Rate:	1 to 20 samples per second, selectable
Load Cells:	(4) 350 ohm strain gauge load cells
Excitation Voltage:	12VDC
Sensitivity:	
NON-COMMERCIAL	0.15 uV/e
NTEP	0.3uV/e (Class III/IIIL)
CANADA	0.3uV/e (Class III/IIHHD)
Scale Divisions:	
NON-COMMERCIAL	100 to 240,000
NTEP	100 to 100,000 (Class III/IIIL)
CANADA	100 to 100,000 (Class III/IIHHD)
Internal Resolution:	1 part in 16,777,216
Transmission Distance	Up to 1 mile Line Of Sight (LOS), Wireless Up to 30 feet, RS232

**SNAP-8S (8300-D026-0A)**

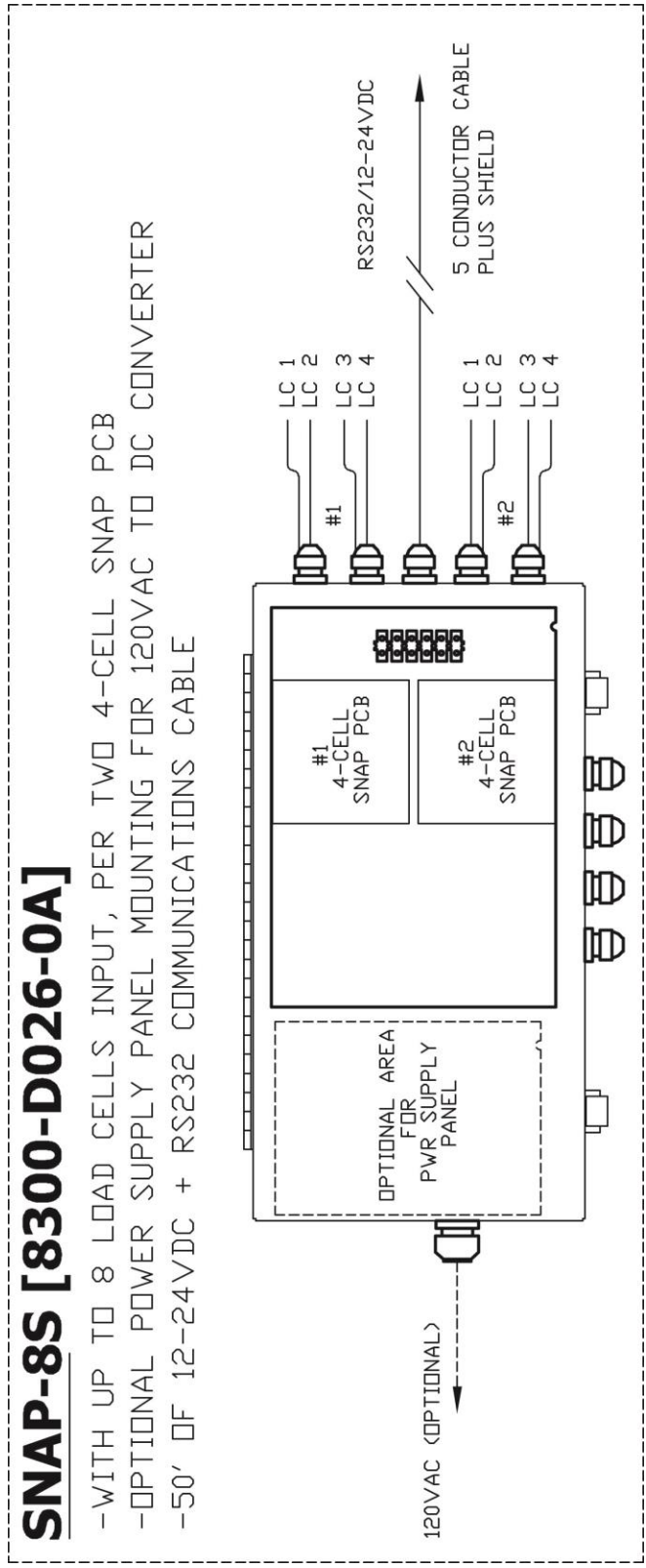



**SNAP-8S (8300-D026-0A)**

Power Requirements:	12-24 VDC at 1.0A Max.
Temperature Range: (Compensated)	-13 to 104 °F (-25 to +40 °C)
Hardware:	Junction-Box Style Scalebox with 2 (4-Cell SNAP PCB) and area for Optional Power Supply Panel 50' of 12-24VDC and RS232 Communications Cable
SNAP-8S Connections:	8 Load Cell Inputs (4 per SNAP PCB), RS232/12-24VDC, 120VAC for Optional Power Supply Panel
Sample Rate:	1 to 20 samples per second, selectable
Load Cells:	(8) 350 ohm strain gauge load cells (4 per SNAP PCB)
Excitation Voltage:	12VDC
Sensitivity:	
NON-COMMERCIAL	0.15 uV/e
NTEP	0.3uV/e (Class III/IIIL)
CANADA	0.3uV/e (Class III/IIHHD)
Scale Divisions:	
NON-COMMERCIAL	100 to 240,000
NTEP	100 to 100,000 (Class III/IIIL)
CANADA	100 to 100,000 (Class III/IIHHD)
Internal Resolution:	1 part in 16,777,216
Transmission Distance	Up to 1 mile Line Of Sight (LOS), Wireless Up to 30 feet, RS232

# SNAP-8

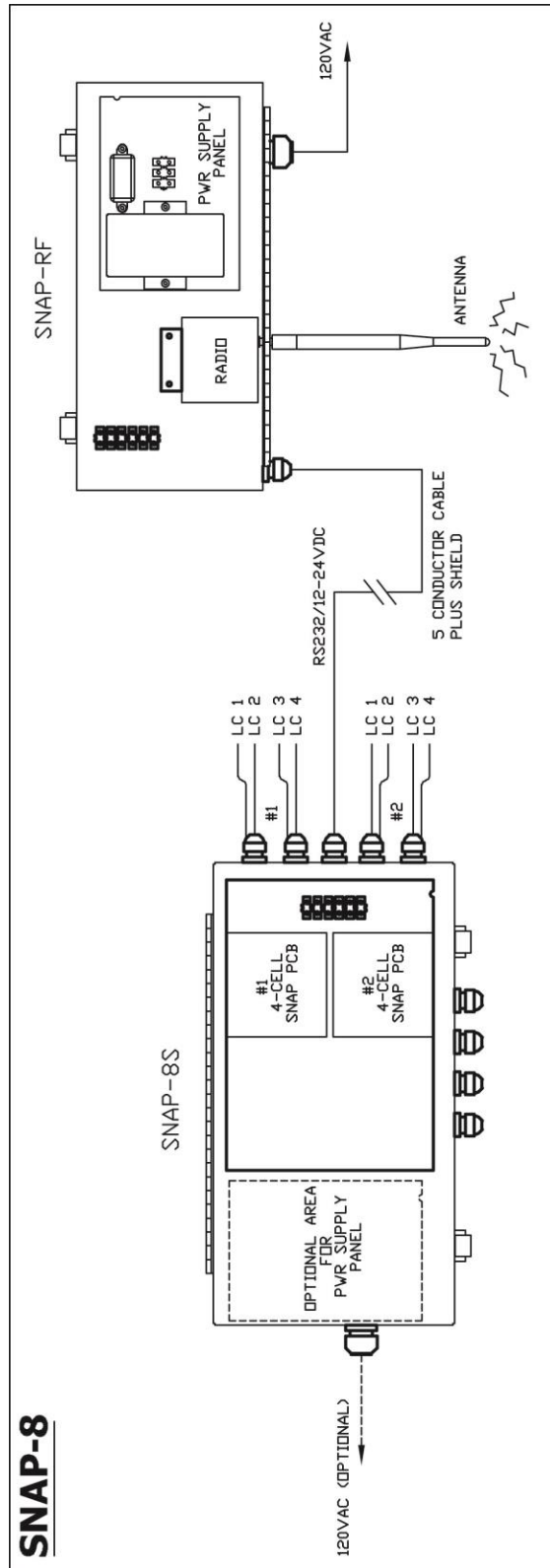

**SNAP-8**

Power Requirements:	12-24 VDC at 1.0A Max.
Temperature Range: (Compensated)	-13 to 104 °F (-25 to +40 °C)
Hardware:	1 SNAP-8S and 1 SNAP-RF
SNAP-8S	8 Load Cell Inputs (4 per SNAP PCB),
Connections:	RS232/12-24VDC to SNAP-RF, 120VAC for Optional Power Supply Panel
SNAP-RF	RS232/12-24VDC from SNAP-8S,
Connections:	Antenna, 120VAC for Power Supply Panel
Sample Rate:	1 to 20 samples per second, selectable
Load Cells:	(8) 350 ohm strain gauge load cells (4 per SNAP PCB)
Excitation Voltage:	12VDC
Sensitivity:	
NON-COMMERCIAL	0.15 uV/e
NTEP	0.3uV/e (Class III/IIIL)
CANADA	0.3uV/e (Class III/IIHHD)
Scale Divisions:	
NON-COMMERCIAL	100 to 240,000
NTEP	100 to 100,000 (Class III/IIIL)
CANADA	100 to 100,000 (Class III/IIHHD)
Internal Resolution:	1 part in 16,777,216
Transmission Distance	Up to 1 mile Line Of Sight (LOS), Wireless Up to 30 feet, RS232

# SNAP-12

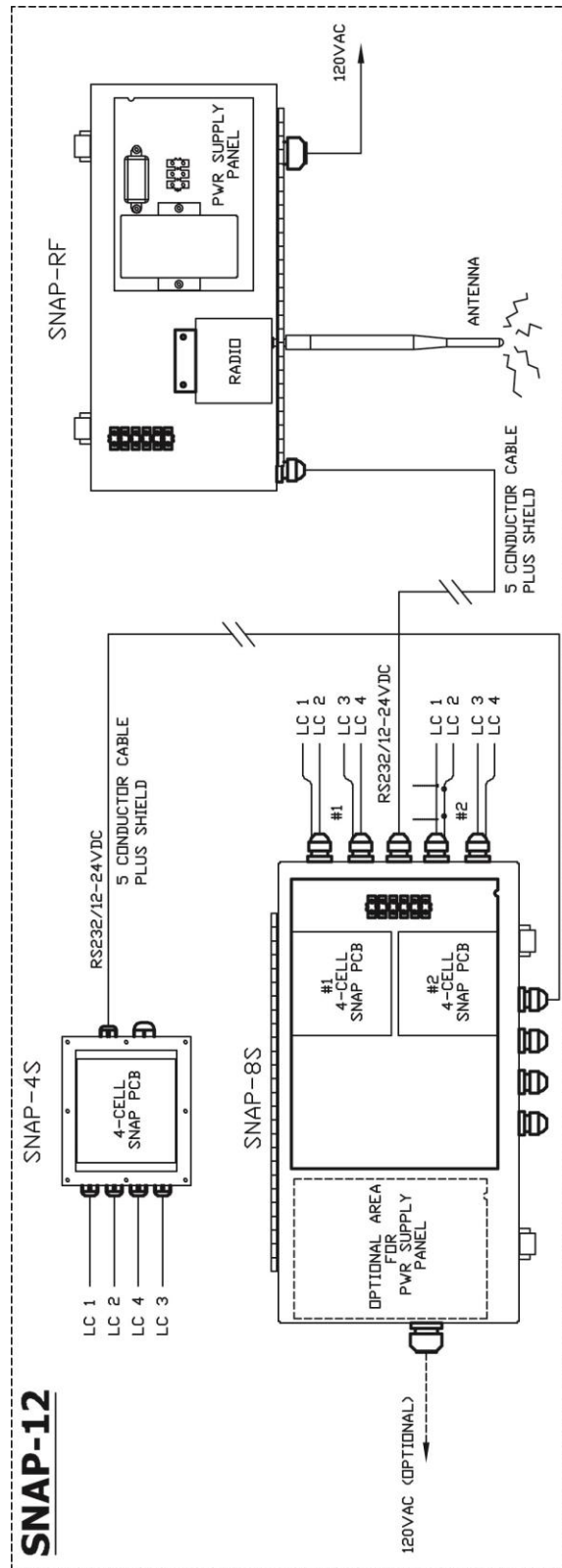

**SNAP-12**

Power Requirements:	12-24 VDC at 1.0A Max.
Temperature Range: (Compensated)	-13 to 104 °F (-25 to +40 °C)
Hardware:	1 SNAP-4S, 1 SNAP-8S and 1 SNAP-RF
SNAP-4S	4 Load Cell Inputs,
Connections:	RS232/12-24VDC to SNAP-8S
SNAP-8S	8 Load Cell Inputs (4 per SNAP PCB),
Connections:	RS232/12-24VDC to SNAP-RF, 120VAC for Optional Power Supply Panel
SNAP-RF	RS232/12-24VDC from SNAP-8S,
Connections:	Antenna, 120VAC for Power Supply Panel
Sample Rate:	1 to 20 samples per second, selectable
Load Cells:	(12) 350 ohm strain gauge load cells (4 per SNAP PCB)
Excitation Voltage:	12VDC
Sensitivity:	
NON-COMMERCIAL	0.15 uV/e
NTEP	0.3uV/e (Class III/IIIL)
CANADA	0.3uV/e (Class III/IIHHD)
Scale Divisions:	
NON-COMMERCIAL	100 to 240,000
NTEP	100 to 100,000 (Class III/IIIL)
CANADA	100 to 100,000 (Class III/IIHHD)
Internal Resolution:	1 part in 16,777,216
Transmission Distance	Up to 1 mile Line Of Sight (LOS), Wireless Up to 30 feet, RS232

# SNAP-16

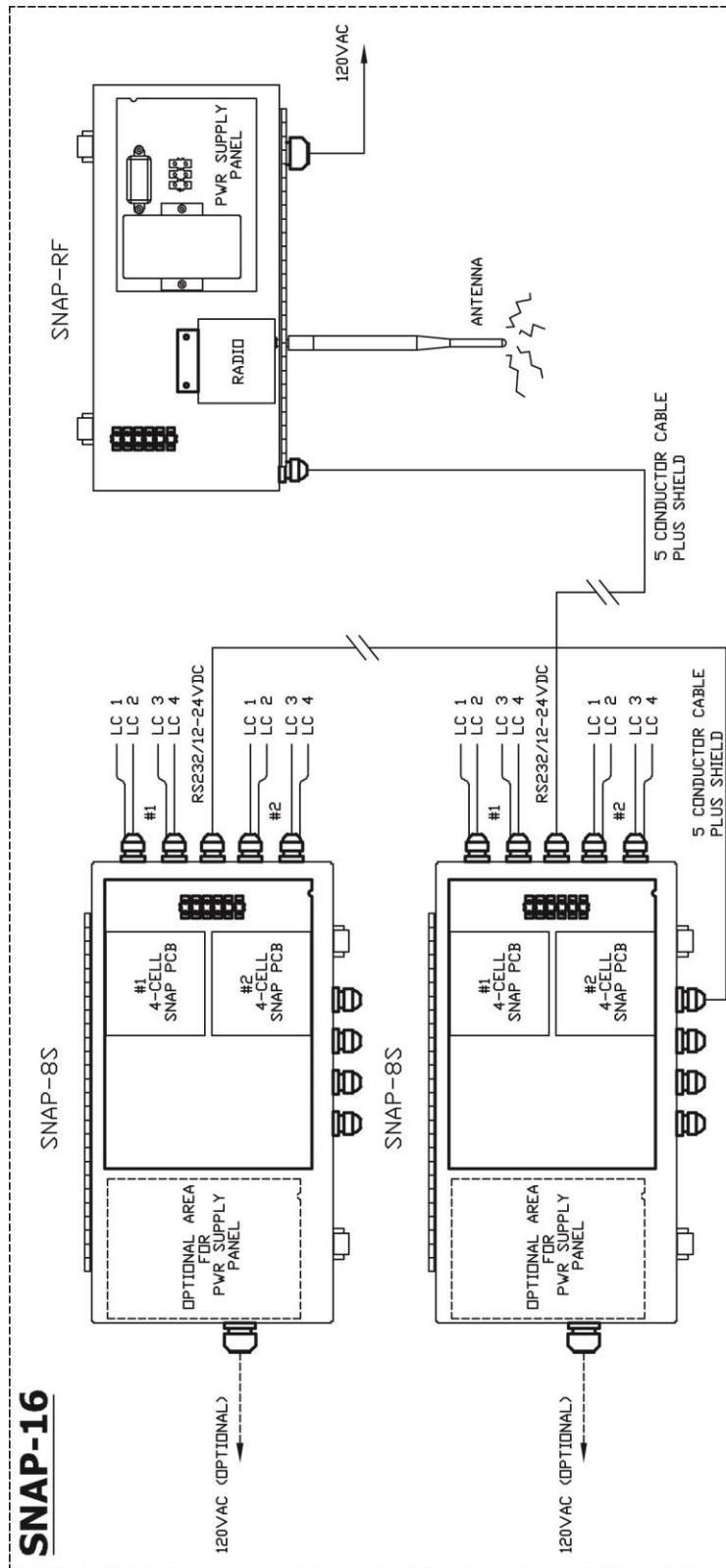

**SNAP-16**

Power Requirements:	12-24 VDC at 1.0A Max.
Temperature Range: (Compensated)	-13 to 104 °F (-25 to +40 °C)
Hardware:	2 SNAP-8S and 1 SNAP-RF
1 <sup>st</sup> SNAP-8S	8 Load Cell Inputs (4 per SNAP PCB),
Connections:	RS232/12-24VDC to SNAP-RF, 120VAC for Optional Power Supply Panel
2 <sup>nd</sup> SNAP-8S	8 Load Cell Inputs (4 per SNAP PCB),
Connections:	RS232/12-24VDC to SNAP-RF, 120VAC for Optional Power Supply Panel
SNAP-RF	RS232/12-24VDC from SNAP-8S,
Connections:	Antenna, 120VAC for Power Supply Panel
Sample Rate:	1 to 20 samples per second, selectable
Load Cells:	(16) 350 ohm strain gauge load cells (8 per SNAP-8S with 4 per SNAP PCB)
Excitation Voltage:	12VDC
Sensitivity:	
NON-COMMERCIAL	0.15 uV/e
NTEP	0.3uV/e (Class III/IIIL)
CANADA	0.3uV/e (Class III/IIHHD)
Scale Divisions:	
NON-COMMERCIAL	100 to 240,000
NTEP	100 to 100,000 (Class III/IIIL)
CANADA	100 to 100,000 (Class III/IIHHD)
Internal Resolution:	1 part in 16,777,216
Transmission Distance	Up to 1 mile Line Of Sight (LOS), Wireless Up to 30 feet, RS232

**SNAP-12S (8300-D026-1A)**

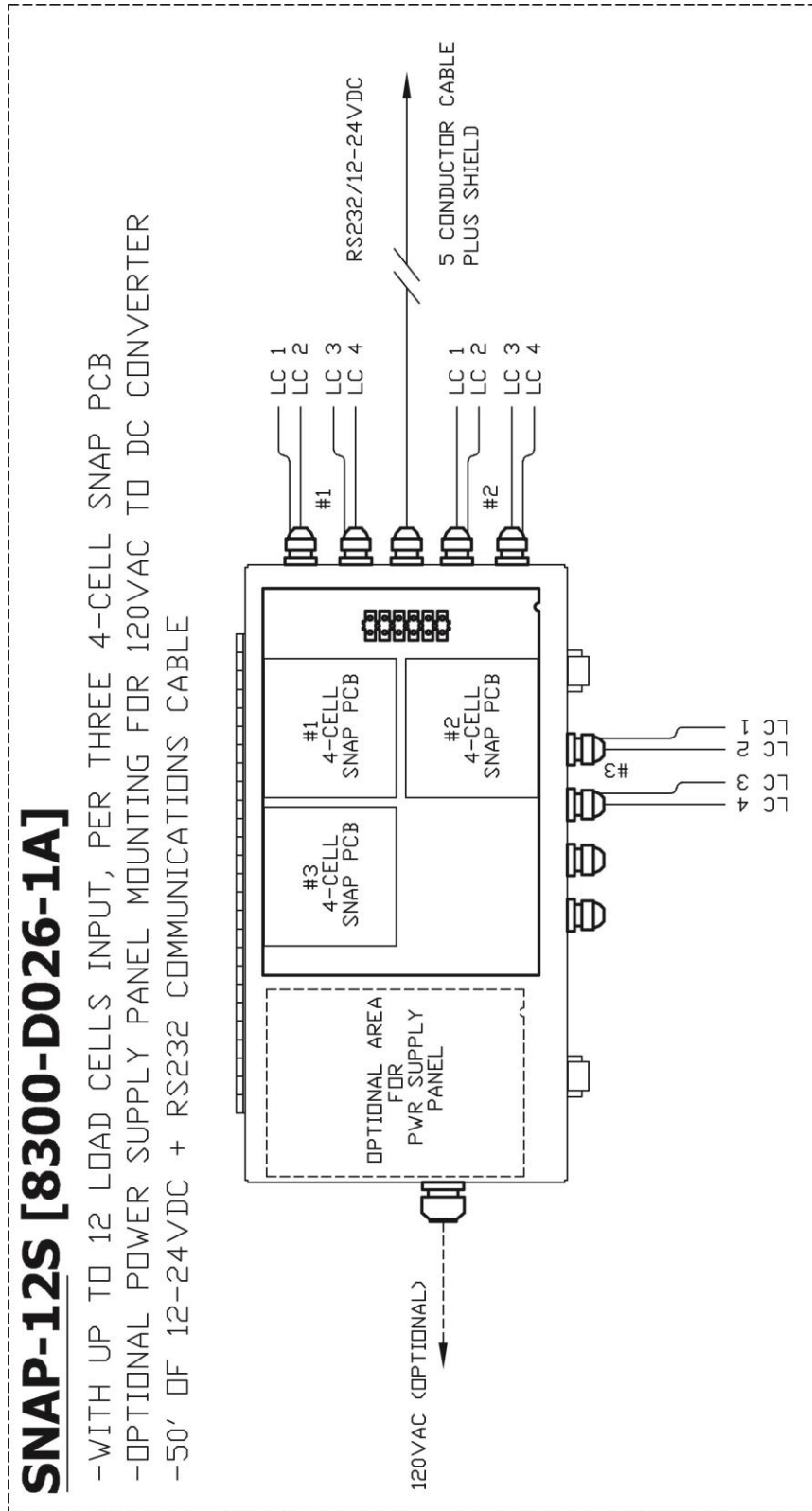



**SNAP 12S (8300-D026-1A)**

Power Requirements:	12-24 VDC at 1.0A Max.
Temperature Range: (Compensated)	-13 to 104 °F (-25 to +40 °C)
Hardware:	Junction-Box Style Scalebox with 3 (4-Cell SNAP PCB) and area for Optional Power Supply Panel 50' of 12-24VDC and RS232 Communications Cable
SNAP-12S Connections:	12 Load Cell Inputs (4 per SNAP PCB), RS232/12-24VDC, 120VAC for Optional Power Supply Panel
Sample Rate:	1 to 20 samples per second, selectable
Load Cells:	(12) 350 ohm strain gauge load cells (4 per SNAP PCB)
Excitation Voltage:	12VDC
Sensitivity:	
NON-COMMERCIAL	0.15 uV/e
NTEP	0.3uV/e (Class III/IIIL)
CANADA	0.3uV/e (Class III/IIIRD)
Scale Divisions:	
NON-COMMERCIAL	100 to 240,000
NTEP	100 to 100,000 (Class III/IIIL)
CANADA	100 to 100,000 (Class III/IIIRD)
Internal Resolution:	1 part in 16,777,216
Transmission Distance	Up to 1 mile Line Of Sight (LOS), Wireless Up to 30 feet, RS232

**SNAP-3x4 / SNAP-10**

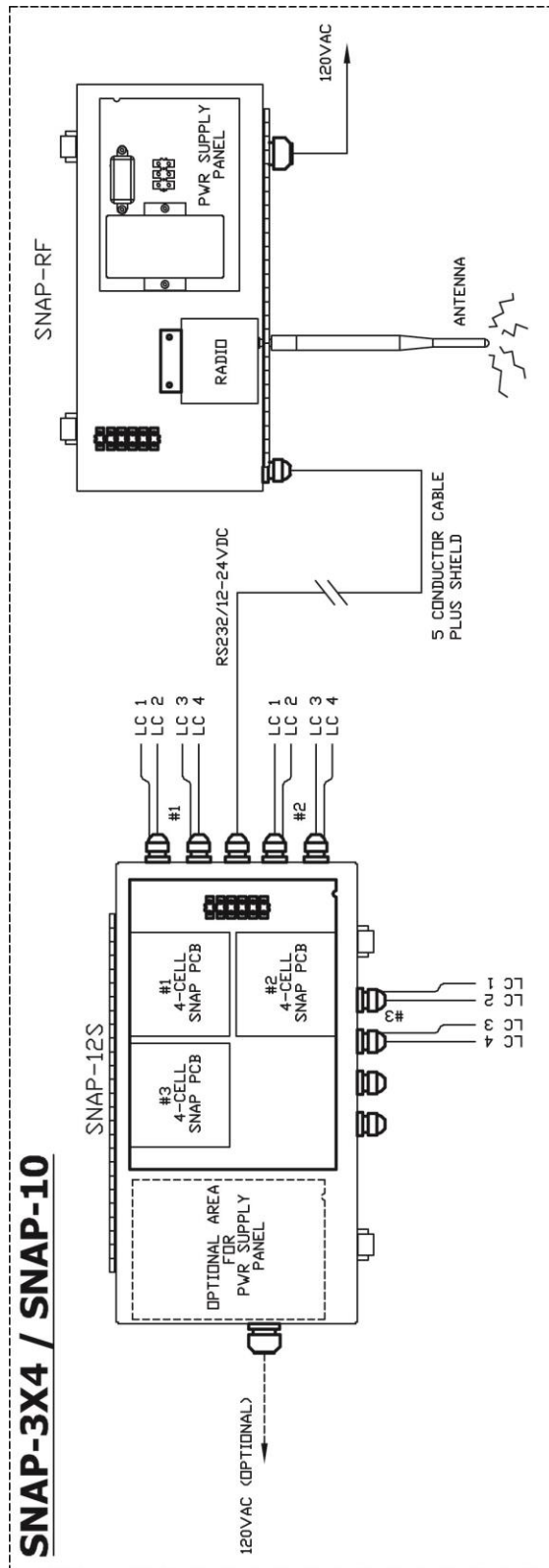

**SNAP-3x4 / SNAP-10**

Power Requirements:	12-24 VDC at 1.0A Max.
Temperature Range: (Compensated)	-13 to 104 °F (-25 to +40 °C)
Hardware:	1 SNAP-12S and 1 SNAP-RF
SNAP-12S	12 Load Cell Inputs (4 per SNAP PCB),
Connections:	RS232/12-24VDC to SNAP-RF, 120VAC for Optional Power Supply Panel
SNAP-RF	RS232/12-24VDC from SNAP-12S,
Connections:	Antenna, 120VAC for Power Supply Panel
Sample Rate:	1 to 20 samples per second, selectable
Load Cells:	(12) 350 ohm strain gauge load cells (4 per SNAP PCB)
Excitation Voltage:	12VDC
Sensitivity:	
NON-COMMERCIAL	0.15 uV/e
NTEP	0.3uV/e (Class III/IIIL)
CANADA	0.3uV/e (Class III/IIIRD)
Scale Divisions:	
NON-COMMERCIAL	100 to 240,000
NTEP	100 to 100,000 (Class III/IIIL)
CANADA	100 to 100,000 (Class III/IIIRD)
Internal Resolution:	1 part in 16,777,216
Transmission Distance	Up to 1 mile Line Of Sight (LOS), Wireless Up to 30 feet, RS232

**SNAP-16S (8300-D026-2A)**

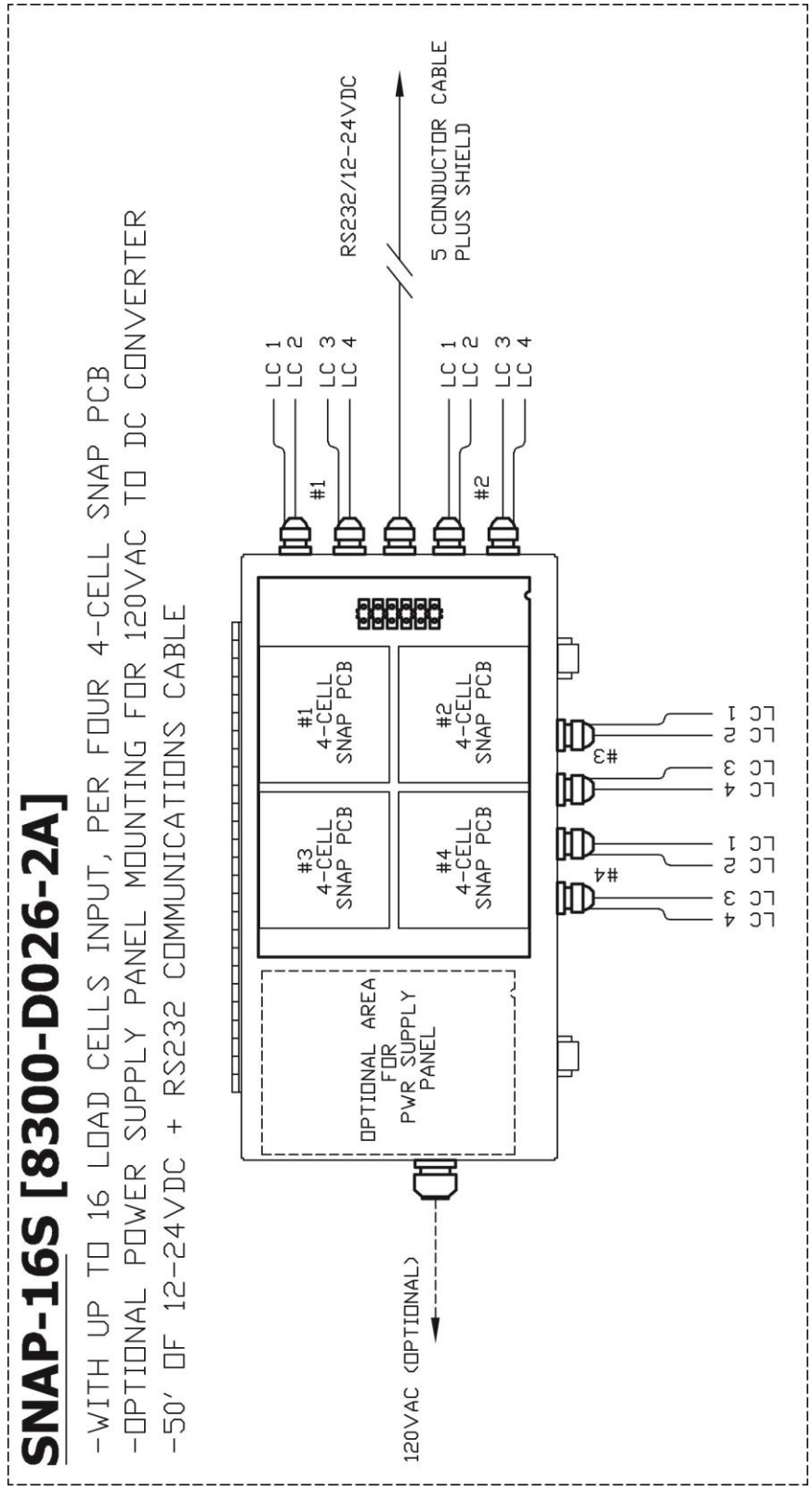

**SNAP-16S (8300-D026-2A)**

Power Requirements:	12-24 VDC at 1.0A Max.
Temperature Range: (Compensated)	-13 to 104 °F (-25 to +40 °C)
Hardware:	Junction-Box Style Scalebox with 4 (4-Cell SNAP PCB) and area for Optional Power Supply Panel 50' of 12-24VDC and RS232 Communications Cable
SNAP-16S Connections:	16 Load Cell Inputs (4 per SNAP PCB), RS232/12-24VDC, 120VAC for Optional Power Supply Panel
Sample Rate:	1 to 20 samples per second, selectable
Load Cells:	(16) 350 ohm strain gauge load cells (4 per SNAP PCB)
Excitation Voltage:	12VDC
Sensitivity:	
NON-COMMERCIAL	0.15 uV/e
NTEP	0.3uV/e (Class III/IIIL)
CANADA	0.3uV/e (Class III/IIIRD)
Scale Divisions:	
NON-COMMERCIAL	100 to 240,000
NTEP	100 to 100,000 (Class III/IIIL)
CANADA	100 to 100,000 (Class III/IIIRD)
Internal Resolution:	1 part in 16,777,216
Transmission Distance	Up to 1 mile Line Of Sight (LOS), Wireless Up to 30 feet, RS232

# SNAP-4X4

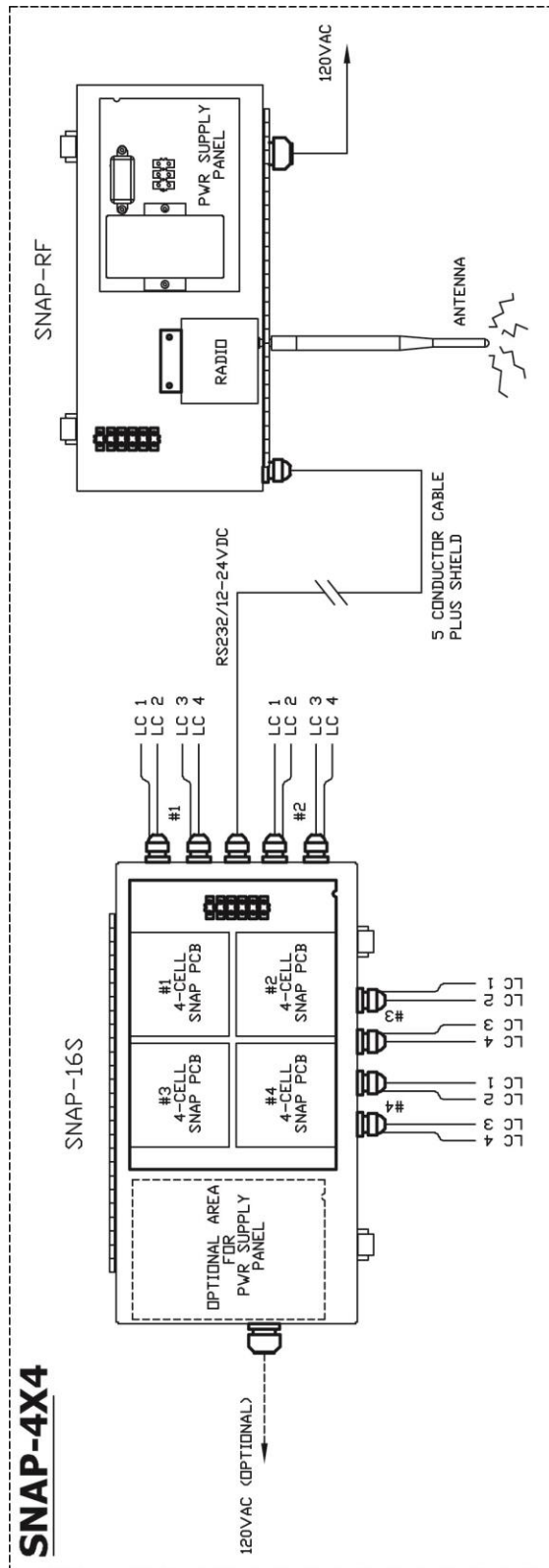

**SNAP-4X4**

Power Requirements:	12-24 VDC at 1.0A Max.
Temperature Range: (Compensated)	-13 to 104 °F (-25 to +40 °C)
Hardware:	1 SNAP-16S and 1 SNAP RF-BOX
SNAP-16S	16 Load Cell Inputs (4 per SNAP PCB),
Connections:	RS232/12-24VDC, 120VAC for Optional Power Supply Panel
SNAP RF-BOX	RS232/12-24VDC from SNAP-12S,
Connections:	Antenna, 120VAC for Power Supply Panel
Sample Rate:	1 to 20 samples per second, selectable
Load Cells:	(16) 350 ohm strain gauge load cells (4 per SNAP PCB)
Excitation Voltage:	12VDC
Sensitivity:	
NON-COMMERCIAL	0.15 uV/e
NTEP	0.3uV/e (Class III/IIIL)
CANADA	0.3uV/e (Class III/IIHHD)
Scale Divisions:	
NON-COMMERCIAL	100 to 240,000
NTEP	100 to 100,000 (Class III/IIIL)
CANADA	100 to 100,000 (Class III/IIHHD)
Internal Resolution:	1 part in 16,777,216
Transmission Distance	Up to 1 mile Line Of Sight (LOS), Wireless Up to 30 feet, RS232

## 2XX-SNAP (8200-C568-0A)

### 2XX-SNAP [8200-C568-0A]

- 1 ANTENNA, CABLE, BRACKET, AND 2XX OPTION CARD KIT
- INSTALLS INTO ANY 2XX SERIES INDICATOR OR SB500/SB250 SERIES SCOREBOARD
- FOR RADIO INPUT/OUTPUT COMMUNICATIONS W/ OTHER SNAP DEVICES

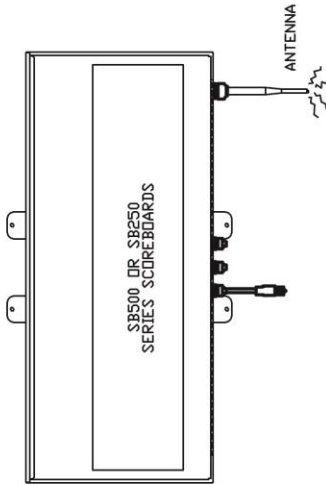
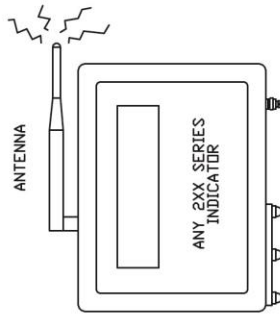
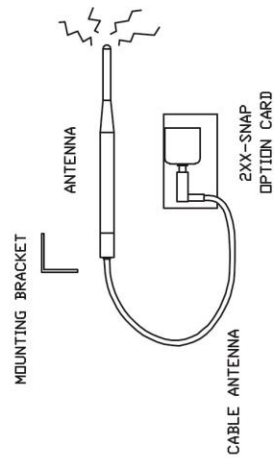



**2XX-SNAP (8200-C568-0A)**

Temperature Range: (Compensated)	-13 to 104 °F (-25 to +40 °C)
Hardware:	1 ANTENNA, Cable, Bracket and 2XX Option Card Kit
Compatibility:	Installs into any 2XX Series Indicator or SB500/SB250 Series Scoreboard
Internal Connections:	1 16-pin dual in-line connector
External Connections:	ANTENNA
Status LED's:	2 LED's – Radio and TX, RX
Transmission Distance	Up to 1 mile Line Of Sight (LOS)

# SNAP-COM (8300-C016-0A)

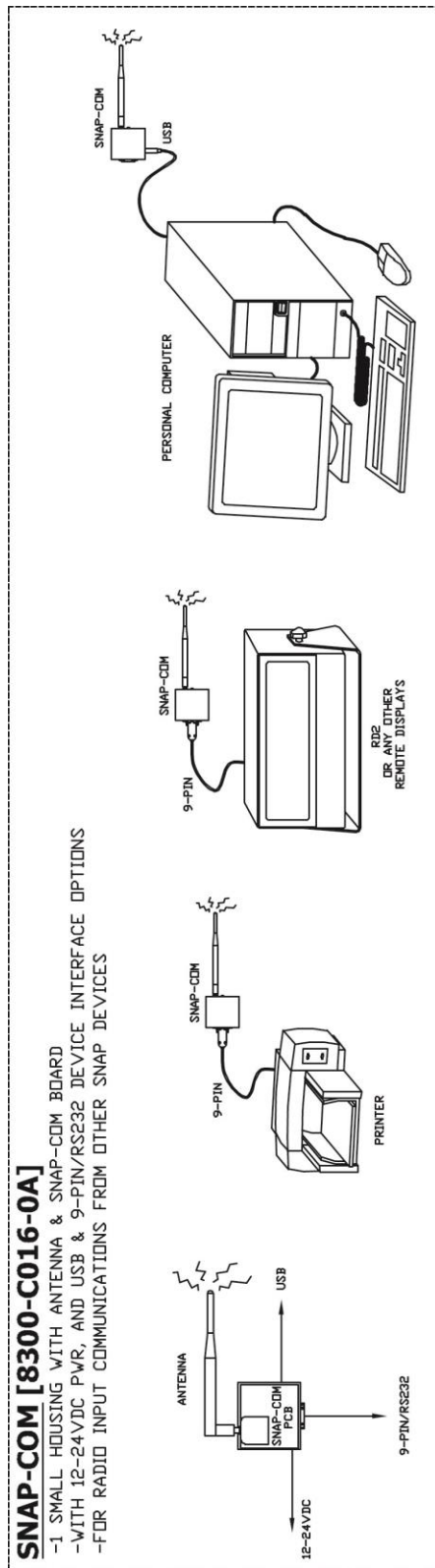

**SNAP-COM (8300-C016-0A)**

Power Requirements:	12 to 24VDC, 300mA
Temperature Range: (Compensated)	-13 to 104 °F (-25 to +40 °C)
Hardware:	1 Small Housing with ANTENNA and SNAP-COM Board
Mounting:	Standard 35 mm DIN Rail (can be rotated 90° to adapt to your installation preference)
Connections:	9-Pin RS232, USB-B (Standard “B” Connector), ANTENNA, POWER: POWER PLUG (mates with Switchcraft 712 Jack w/.0.100” (2.5mm) Pin, Center Pin Positive)
Serial Interface:	300 to 921,600 bps RS-232 Level, DTE/DCE (Switch selectable), RTS-CTS, DSR-DTR Handshaking (Jumper selectable)
USB Interface	Device (or upstream) port.
Transmission Distance	Up to 1 mile Line Of Sight (LOS)

## SNAP-COMIP (8300-C016-1A)

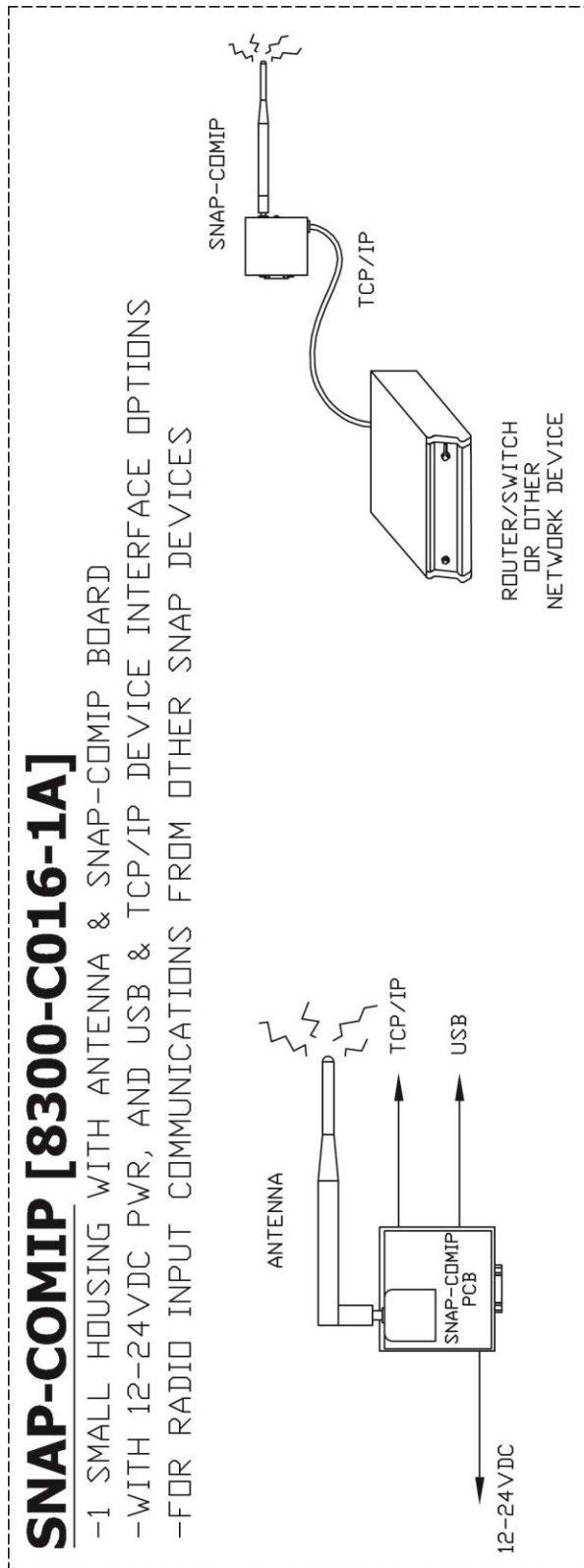

**SNAP-COMIP (8300-C016-1A)**

Power Requirements:	12 to 24VDC, 300mA
Temperature Range: (Compensated)	-13 to 104 °F (-25 to +40 °C)
Hardware:	1 Small Housing with ANTENNA and SNAP-COM Board
Mounting:	Standard 35 mm DIN Rail (can be rotated 90° to adapt to your installation preference)
Connections:	RJ-45 Ethernet, USB-B (Standard “B” Connector), ANTENNA, POWER: POWER PLUG (mates with Switchcraft 712 Jack w/.0.100” (2.5mm) Pin, Center Pin Positive)
Network Interface:	10BASE-T or 100BASE-TX (auto sensing) Ethernet 2.0, IEEE 802.3 ARP, UDP/IP, TCP/IP, Telnet, ICMP, SNMP, DHCP, BOOTP TFTP, Auto IP, and HTTP
USB Interface	Device (or upstream) port.
Transmission Distance	Up to 1 mile Line Of Sight (LOS)



## PRECAUTIONS

### Static Electricity



**CAUTION!** These devices contain static sensitive circuit cards and components. Improper handling of these devices or printed circuit cards can result in damage to or destruction of the component or card. Such actual and/or consequential damage **IS NOT** covered under warranty and is the responsibility of the device owner. Electronic components must be handled only by qualified electronic technicians who follow the guidelines listed below.



**ATTENTION!** ALWAYS use a properly grounded wrist strap when handling, removing or installing electronic circuit cards or components. Make certain that the wrist strap ground lead is securely attached to an adequate ground. If you are uncertain of the quality of the ground, you should consult a licensed electrician.



**ALWAYS** handle printed circuit card assemblies by the outermost edges.

**NEVER** touch the components, component leads or connectors.

**ALWAYS** observe warning labels on static protective bags and packaging and never remove the card or component from the packaging until ready for use.

**ALWAYS** store and transport electronic printed circuit cards and components in anti-static protective bags or packaging.





# INSTALLATION

## Site Preparation Requirements

The SnapStream Series requires an acceptable environment to operate at peak performance and reliability. This section is provided to assist you in obtaining such an environment.

## Environmental

The SnapStream Series meets or exceeds all operating requirements within a temperature range of -13 to 104 °F (-25 to +40 °C).

## Electrical Power

The SNAP-RF has been designed to operate from 100 to 240 VAC (50/60 Hz) at 0.4A Max..

The SNAP-4S, 8S, 12S, and 16S has been designed to operate from 12 to 24VDC at 1.0A Max. provided by the SNAP-RF or from an optional 100 to 240 VAC (50/60 Hz) at 0.4A Max. power supply.

The SNAP-4R has been designed to operate from 12 to 24VDC at 1.0A Max. from an external power source.

The SNAP-COM/SNAP-COMIP has been designed to operate from 12 to 24VDC at 1.0A Max. using a AC Power Adapter (Cardinal part number 6610-1045).

The 2XX-SNAP operates from power provided by the 2XX indicator or SB500/SB250 scoreboard main board.

## Transient Suppression

The following recommendations will help to reduce transients:

- Always use shielded cables to connect signal/power between the SNAP-4S, 8S, 12S, and 16S and the SNAP-RF.
- Keep wires that extend beyond the shield as short as possible.
- Do not run signal/power cables along side or parallel to wiring carrying AC power. If unavoidable, position the signal/power cables a minimum of 24" away from all AC wiring.



## WIRING THE SNAP-4R

### SNAP-4R

- 1 SNAP-4S
- WITH RADIO, ANTENNA & CABLE FOR WIRELESS OUTPUT

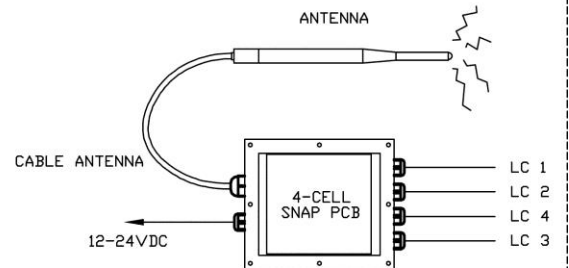

1. Remove the 8 screws securing the cover and remove the cover.
2. Loosen the 4 gland connectors on the side of the junction box to allow each load cell cable to be easily inserted.
3. Insert the cable from each load cell through the gland connector and into the enclosure.
4. Referring to the illustration on the right, remove 3 inches of the outer insulation jacket.
5. Next, remove 3/16 inch of insulation from each of the four wires and shield.
6. Connect each of the wires to terminal block referring to the labels on circuit board for terminal connections.
7. Referring to the table on the next page and the labels on the circuit board for terminal connections, connect each wire to the terminal block.
8. To terminate a wire, press down on release bar for the terminal, insert wire into terminal opening then allow release bar to return to its original position, locking wire in place.
9. Continue the procedure until all wires are in place for the load cell.
10. Repeat steps 4 through 9 for each load cell.
11. After all connections to the SNAP-4R board have been made, remove the excess cable from the enclosure.

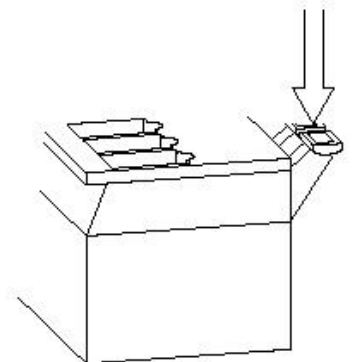
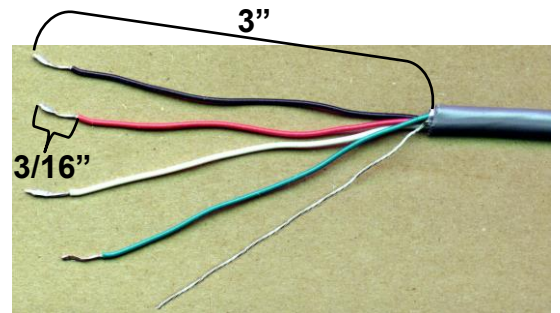

### Snap-4R/Snap-4S Load Cell Wiring Table

Board Label	Load Cell 1 Function
<b>+EXC1</b>	+ EXCITATION
<b>+SIG1</b>	+ SIGNAL
<b>-SIG1</b>	- SIGNAL
<b>-EXC1</b>	- EXCITATION
<b>SHLD</b>	SHIELD

Board Label	Load Cell 2 Function
<b>+EXC2</b>	+ EXCITATION
<b>+SIG2</b>	+ SIGNAL
<b>-SIG2</b>	- SIGNAL
<b>-EXC2</b>	- EXCITATION
<b>SHLD</b>	SHIELD

Board Label	Load Cell 3 Function
<b>+EXC3</b>	+ EXCITATION
<b>+SIG3</b>	+ SIGNAL
<b>-SIG3</b>	- SIGNAL
<b>-EXC3</b>	- EXCITATION
<b>SHLD</b>	SHIELD

Board Label	Load Cell 4 Function
<b>+EXC4</b>	+ EXCITATION
<b>+SIG4</b>	+ SIGNAL
<b>-SIG4</b>	- SIGNAL
<b>-EXC4</b>	- EXCITATION
<b>SHLD</b>	SHIELD

### Snap-4R/Snap-4S Communicartion Cable Wiring Table

Board Label	Wire Color
<b>TX0</b>	RED
<b>RX0</b>	WHITE
<b>TX1</b>	N/C
<b>RX1</b>	N/C
<b>GND</b>	BLACK
<b>GND</b>	BROWN
<b>10-30</b>	GREEN

### Snap-4R/Snap-4S Internal View

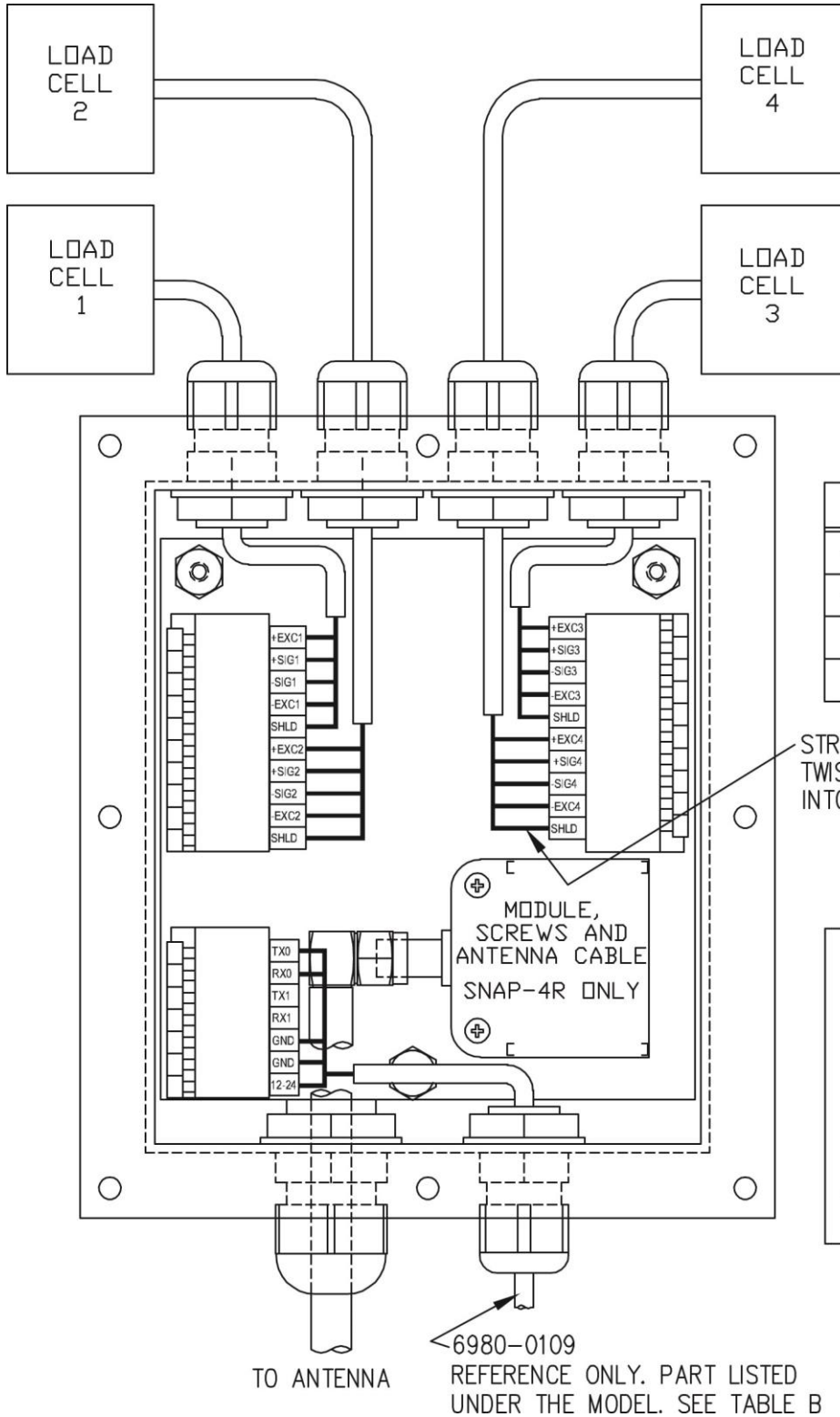

LOAD CELL COLOR CODE TABLE A

WIRE	CARDINAL COLOR CODE	WEST COAST COLOR CODE
+EXC	GREEN	RED
-EXC	BLACK	BLACK
+SIG	RED	GREEN
-SIG	WHITE	WHITE

TABLE B 50' CABLE

TX0	RED
RX0	WHT
GND	BLK
	SHIELD
GND	BRN
12-24V	GRN

## Re-Installing the SNAP-4R Cover

After all terminations have been made, remove the excess cable from the enclosure and securely tighten each of the cable gland connectors. Do not over-tighten these connectors but make certain they are snug. **DO NOT USE TOOLS!** Finger-tighten only! Insure any unused gland connectors are plugged. Make certain no cables or wires are exposed between the enclosure and the cover and then place the cover onto the enclosure. Secure with the 8 screws removed earlier.

# WIRING THE SNAP-4

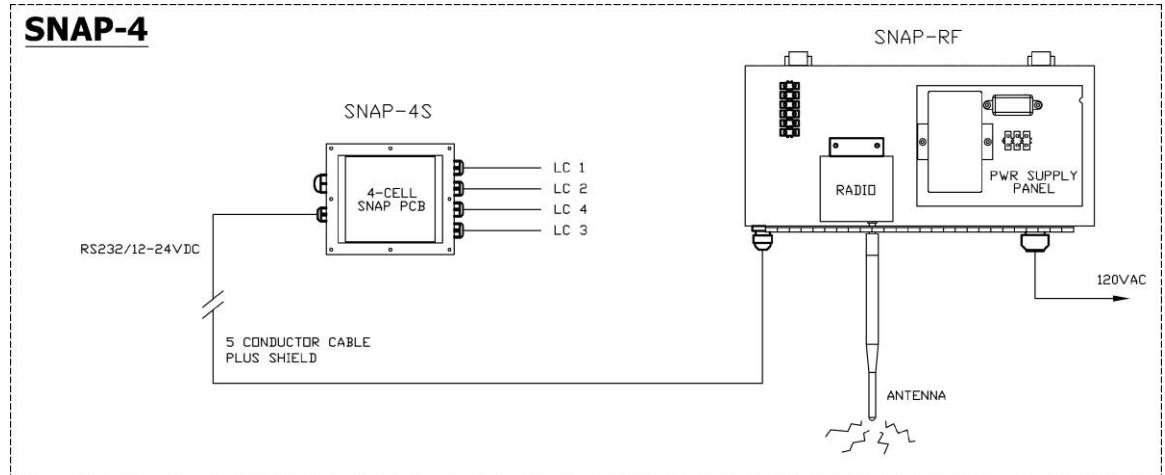

1. Remove the 8 screws securing the SNAP-4S cover and remove cover.
2. Loosen the 4 gland connectors on the side of the junction box to allow each load cell cable to be easily inserted.
3. Insert the cable from each load cell through the gland connector and into the enclosure.

4. Referring to the illustration on the right, remove 3 inches of the outer insulation jacket.
5. Next, remove 3/16 inch of insulation from each of the four wires and shield.

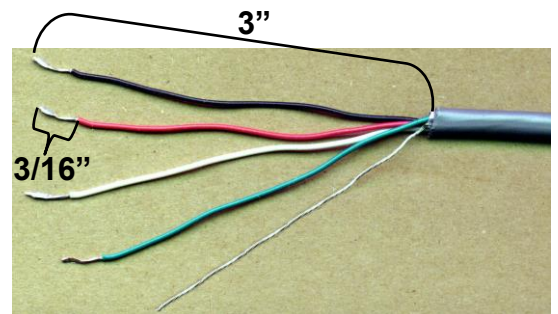

6. Connect each of the wires to terminal block referring to the labels on circuit board for terminal connections.
7. Referring to the table on page 42 and the labels on the circuit board for terminal connections, connect each wire to the terminal block.
8. To terminate a wire, press down on release bar for the terminal, insert wire into terminal opening then allow release bar to return to its original position, locking wire in place.
9. Continue the procedure until all wires are in place for the load cell.
10. Repeat steps 4 through 9 for each load cell.
11. After all connections to the SNAP PCB have been made, remove the excess cable from the enclosure.

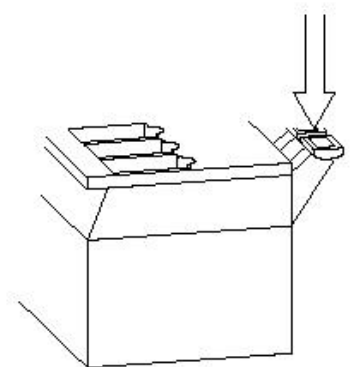

## Re-Installing the SNAP-4S Cover

After all terminations have been made, remove the excess cable from the enclosure and securely tighten each of the cable gland connectors. Do not over-tighten these connectors but make certain they are snug. **DO NOT USE TOOLS!** Finger-tighten only! Insure any unused gland connectors are plugged. Make certain no cables or wires are exposed between the enclosure and the cover and then place the cover onto the enclosure. Secure with the 8 screws removed earlier.

## Connecting the SNAP-4 to the SNAP-RF

1. Begin by releasing the 2 clamps opposite the hinge and swing the cover open on the SNAP-RF.
2. There is a 50' six conductor that is provided with every SNAP-4S to connect the scale box to the RF box. Use this cable to connect the terminal block in the SNAP-4S.

SNAP-RF Terminal	Wire Color
1	RED
2	WHITE
3	BLACK
4	N/C
5	BROWN & SHIELD
6	GREEN

3. Connect the provided antenna to the SNAP-RF.
4. Plug the AC power cord into a clean 120 VAC outlet.
5. Check the analog error LED's on the 4-Cell SNAP PCB to make sure connections are correct and load cells are ok.



## WIRING THE SNAP-4LF

### SNAP-4LF [8300-D059-0A]

- WITH UP TO 4 LOAD CELLS INPUT,  
PER ONE 4-CELL SNAP PCB
- POWER SUPPLY FOR 120VAC TO DC CONVERTER
- 50' OF 12-24VDC + RS232 COMMUNICATIONS CABLE

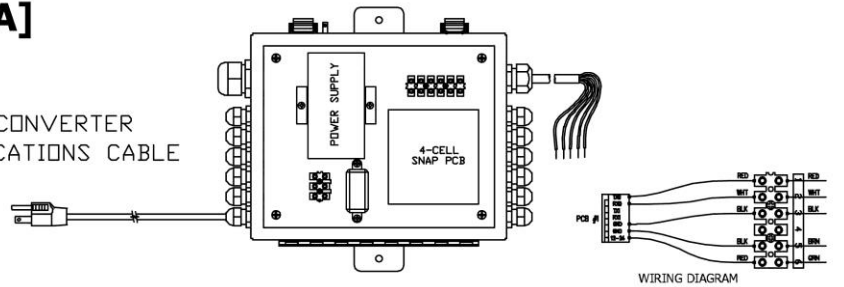

1. Begin by releasing the 2 clamps opposite the hinge and swing the cover open on the SNAP-4LF.
2. Loosen the 4 gland connectors on the side of the junction box to allow each load cell cable to be easily inserted.
3. Insert the cable from each load cell through the gland connector and into the enclosure.
4. Referring to the illustration on the right, remove 3 inches of the outer insulation jacket.
5. Next, remove 3/16 inch of insulation from each of the four wires and shield.
6. Connect each of the wires to terminal block referring to the labels on circuit board for terminal connections.
7. Referring to the table on page 42 and the labels on the circuit board for terminal connections, connect each wire to the terminal block.
8. To terminate a wire, press down on release bar for the terminal, insert wire into terminal opening then allow release bar to return to its original position, locking wire in place.
9. Continue the procedure until all wires are in place for the load cell.
10. Repeat steps 4 through 9 for each load cell.
11. After all connections to the SNAP PCB have been made, remove the excess cable from the enclosure.

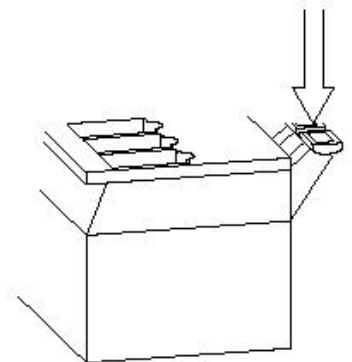
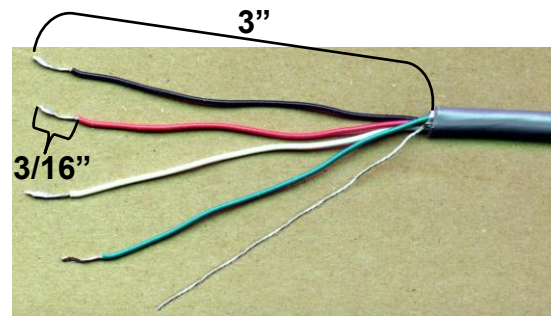

## Connecting SNAP-4LF to SNAP-RADIO JUNCTION BOX

1. Remove the 8 screws securing the SNAP-RADIO JUNCTION BOX cover and remove cover.
2. There is a 50' six conductor that is provided with every SNAP-4LF to connect between the scale box and the SNAP-RADIO JUNCTION BOX. Use the cable to connect the terminal blocks in both boxes, 1 to 1, 2 to 2 and so on.
3. Connect the provided antenna to the SNAP-RADIO JUNCTION BOX.
4. Plug the AC power cord of the SNAP-4LF into a clean 120 VAC outlet.
5. Check the analog error LED's on the 4-Cell SNAP PCB to make sure connections are correct and load cells are ok.

## Re-Installing the SNAP-RADIO JUNCTION BOX Cover

After all terminations have been made, remove the excess cable from the enclosure and securely tighten each of the cable gland connectors. Do not over-tighten these connectors but make certain they are snug. **DO NOT USE TOOLS!** Finger-tighten only! Insure any unused gland connectors are plugged. Make certain no cables or wires are exposed between the enclosure and the cover and then place the cover onto the enclosure. Secure with the 8 screws removed earlier.

## WIRING THE SNAP-12

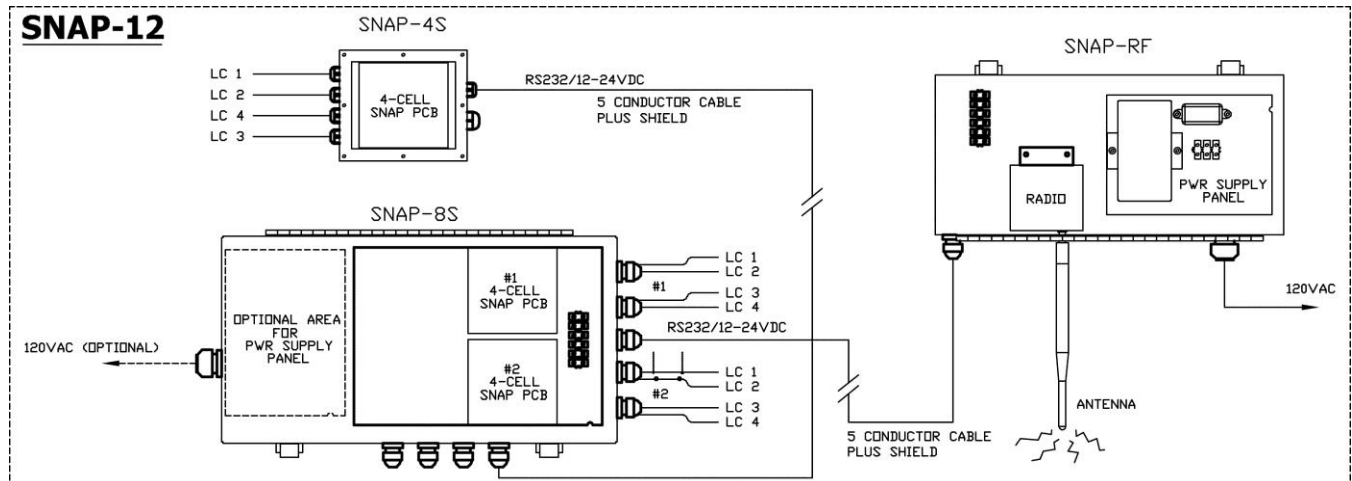

### Wiring the SNAP-4S

1. Remove the 8 screws securing the SNAP-4S cover and remove cover.
2. Loosen the 4 gland connectors on the side of the junction box to allow each load cell cable to be easily inserted.
3. Insert the cable from each load cell through the gland connector and into the enclosure.
4. Remove 3 inches of the outer insulation jacket.
5. Next, remove 3/16 inch of insulation from each of the four wires and shield.
6. Referring to the table on page 42 and the labels on the circuit board for terminal connections, connect each wire to the terminal block.
7. Continue the procedure until all wires are in place for the load cell.
8. Repeat steps 4 through 7 for each load cell.
9. There is a 50' six conductor that is provided with every SNAP-4S to connect the scale boxes. Use this cable to connect the terminal block in the SNAP-4S to the terminal block in the SNAP-8S.

### Re-Installing the SNAP-4S Cover

After all terminations have been made, remove the excess cable from the enclosure and securely tighten each of the cable gland connectors. Do not over-tighten these connectors but make certain they are snug. **DO NOT USE TOOLS!** Finger-tighten only! Insure any unused gland connectors are plugged. Make certain no cables or wires are exposed between the enclosure and the cover and then place the cover onto the enclosure. Secure with the 8 screws removed earlier.

## Wiring the SNAP-8S

1. Begin by releasing the 2 clamps opposite the hinge and swing the cover open on the SNAP-8S and SNAP-RF.
2. There is a 50' six conductor that is provided with every SNAP-8S to connect the scale box to the RF box. Use this cable to connect the terminal blocks in boxes, 1 to 1, 2 to 2 and so on.
3. The above drawing shows the terminal blocks, PCB's and gland connectors that will be used to wire your scale.

Use the following table to make sure your address jumpers are correct.

	<b>ADDR0</b>	<b>ADDR1</b>
<b>PCB # 1</b>	OFF	OFF
<b>PCB # 2</b>	ON	OFF

4. Connect load cells 1-4 to PCB 1 and 5-8 to PCB 2.
5. Connect the provided antenna to the SNAP-RF.
6. Plug the AC power cord into a clean 120 VAC outlet.
7. Check the analog error LED's on the 4-Cell SNAP PCB's to make sure connections are correct and load cells are ok.

## WIRING THE SNAP-8, -3X4/SNAP-10, SNAP-4X4

1. Begin by releasing the 2 clamps opposite the hinge and swing the cover open on the SNAP-8S, 12S, 16S and SNAP-RF.
2. There is a 50' six conductor that is provided with every SNAP-8S, 12S, and 16S to connect the scale box to the RF box. Use this cable to connect the terminal blocks in boxes, 1 to 1, 2 to 2 and so on.
3. The following drawing is a SNAP-4X4 and shows the terminal blocks, PCB's and gland connectors that will be used to wire your scale. The other SNAP systems are the same except have fewer PCB's.

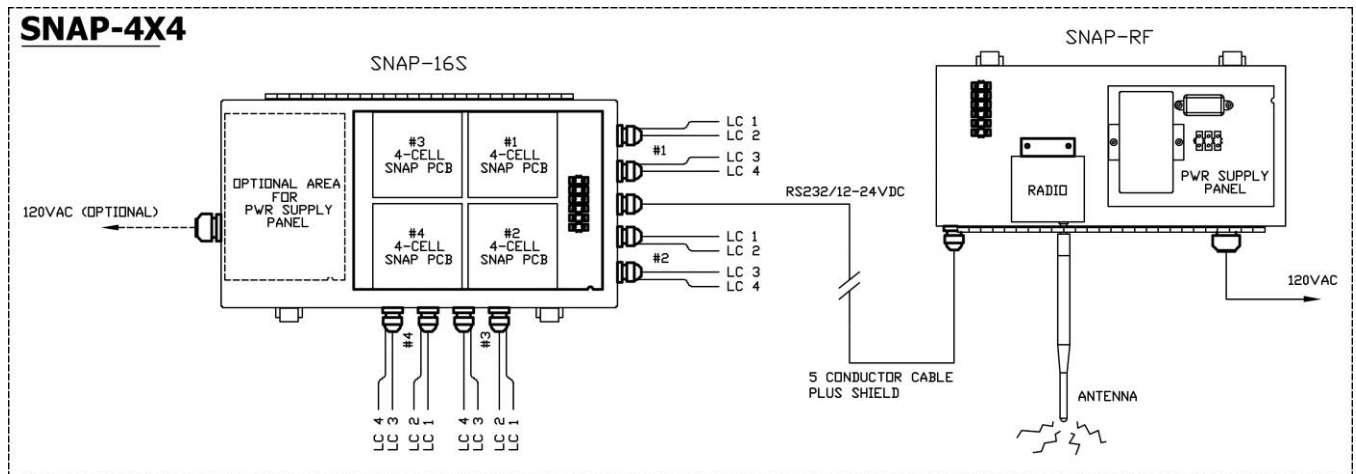

Use the following table to make sure your address jumpers are correct.

	ADDR0	ADDR1
<b>PCB # 1</b>	OFF	OFF
<b>PCB # 2</b>	ON	OFF
<b>PCB # 3</b>	OFF	ON
<b>PCB # 4</b>	ON	ON

4. Connect load cells 1-4 to PCB 1, 5-8 to PCB 2, 9-12 to PCB 3 and 13-16 to PCB 4.
5. Connect the provided antenna to the SNAP-RF.
6. Plug the AC power cord into a clean 120 VAC outlet.
7. Check the analog error LED's on the 4-Cell SNAP PCB's to make sure connections are correct and load cells are ok.



## WIRING THE SNAP-16

1. Begin by releasing the 2 clamps opposite the hinge and swing the cover open on both SNAP-8S's and the SNAP-RF.
2. There is a 50' six conductor that is provided with every SNAP-8S assembly to connect between the scale boxes and to connect one scale box to the RF box. Use these cables to connect the terminal blocks in both SNAP-8S's, 1 to 1, 2 to 2 and so on.
3. Use these cables to connect the terminal block in one SNAP-8 (1 to 1, 2 to 2 and so on) to the SNAP-RF.
4. The following drawing is a SNAP-16 and shows the terminal blocks, PCB's and gland connectors that will be used to wire your scale.

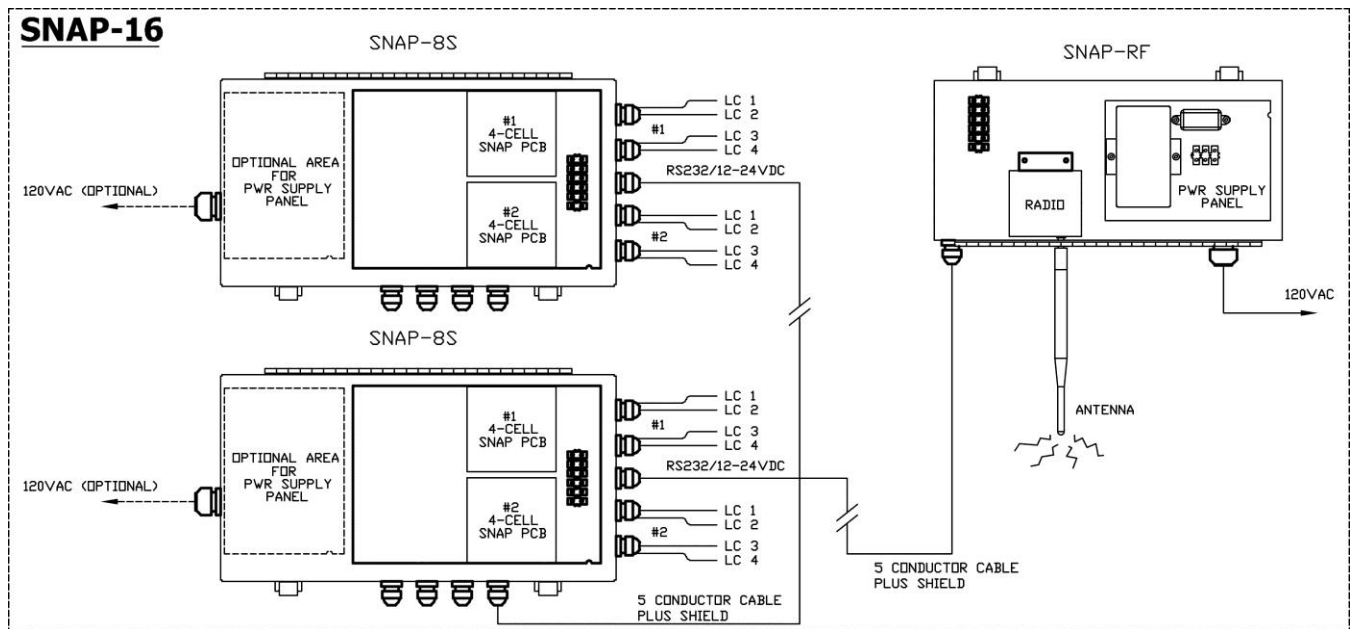

Use the following table to make sure your address jumpers are correct. The boxes are not labeled as box1 or box2. The address jumpers define which box is box1 or box2.

BOX1	ADDR0	ADDR1	BOX2	ADDR0	ADDR1
PCB # 1	OFF	OFF	PCB # 1	OFF	ON
PCB # 2	ON	OFF	PCB # 2	ON	ON

5. Connect load cells 1-4 to PCB 1 BOX1, 5-8 to PCB 2 BOX1, 9-12 to PCB 1 BOX2 and 13-16 to PCB 2 BOX2.
6. Connect the provided antenna to the SNAP-RF.
7. Plug the AC power cord into a clean 120 VAC outlet.
8. Check the analog error LED's on the 4-Cell SNAP PCB's to make sure connections are correct and load cells are ok.





# SNAP-4R SETUP

## USING 205, 210 OR 215

Use the \* key on a 205 to scroll through numbers and letters for addresses and the **UNITS** key to move the cursor. Refer to the illustration below to show where the letters are on a 210 or 215 for entering in addresses for SNAP-4R scales.

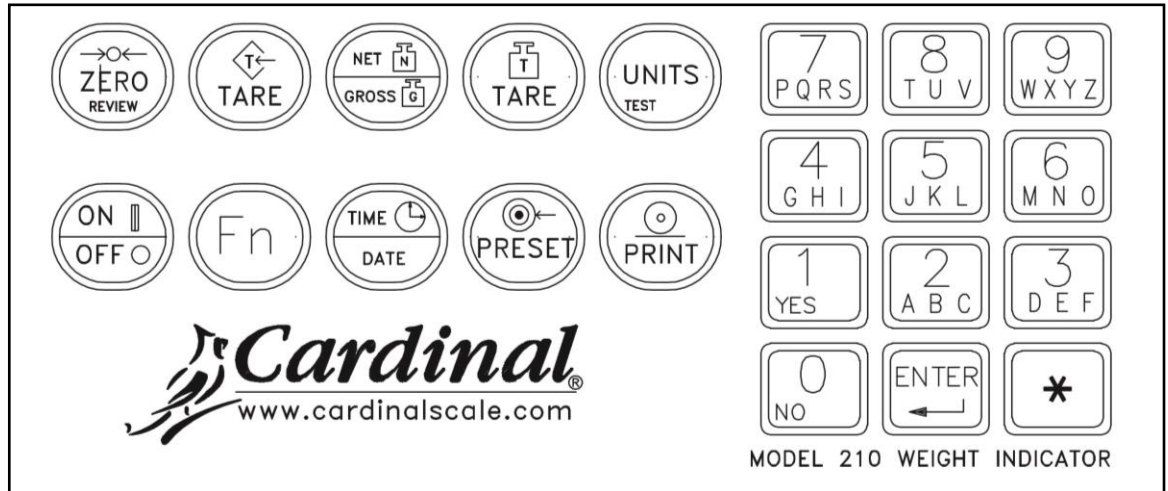

(Updated Keypad – 205/210 with onboard USB)

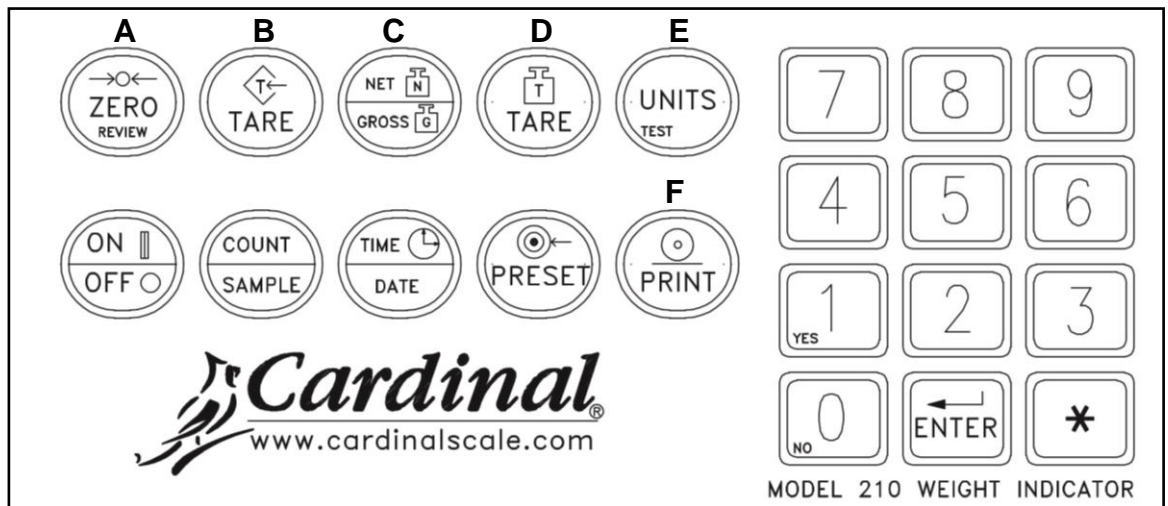

(Legacy Keypad – 205/210/215)

**NOTE:** This section is written assuming you have a working 2XX-SNAP inserted in the indicator.

Press the cal button until the *R-d* prompt and press enter. The following is a description of the applicable prompts:

- SCLSrc* This prompt is asking if you are using a 4 Cell SNAP system or a 1 Cell SNAP system. Enter a 4 for 4 Cell SNAP.
- CELLS:* This prompt is asking how many load cells are being used total for all scales or network of scales. This can be a number from 1-16.
- Addr 1:* This is asking for the address of the radio for the SNAP-4R with the jumpers in the SCALE #1 position. The indicator will divide the number of load cells by 4 and ask for that many addresses. e.g., 12 load cells must have 3 addresses. 7 load cells must have 2 addresses. After entering the radio address for scale one you will be asked *Addr 2:* if you have more than 4 load cells in your network. Enter the applicable radio address for the scale #.
- dFlt:* Same as in the 200 series manual
- Sr:* This is the sample rate of the analog section. This number can be set from 1 to 20.
- UnS:* Same as in the 200 series manual.
- SC:* Same as in the 200 series manual.

The screen will show *-bUSy-* then flash *PR rEd*. If indicator shows failed it will return to the prompt that had failed. Check to make sure address is correct.

- SNPCAL* 0 is for no CAL. 1 is for smartcal and 2 is for 2-point cal.
- TESTLd* Enter the weight of the test load.
- UnLoAd* Unload the scale and press enter.
- LoAd* Load the scale. If using Smart Cal, *LoAd* will change to *LoAd 1* and will increment for each load cell. You will need to load each individual load cell following the on screen prompts.
- SUCCESS* This will flash on the screen for a short while telling you that the scale has been calibrated successfully.

## MAKING LOAD CELL ADJUSTMENTS USING 205, 210 OR 215

### CELL ADJUST (*cELAdj*)

This prompt will immediately follow *SnPCAL* if 0 is selected. It will also be the next prompt displayed immediately following a calibration. It will allow you to “tweak” the weight of individual or pairs of load cells up or down.

*cELAdj*            0 = Don't Adjust Cells (skips prompt)  
                          1 = Single Load Cell Adjustment Menu  
                          2 = Dual Load Cell Adjustment Menu

To access this menu;

1. Go to the CAL section of SETUP.
2. Press the **ENTER** key to step past *SnPCAL*.
3. Enter 1 or 2 at the *cELAdj* prompt.
4. The indicator will display the cell or cell pair that can be adjusted.

1 = *CELL01* (cell 01)                      2 = *01\_02* (01\_02)

5. Position the test weight on displayed cell or cell pair and then press the **ENTER** key.
6. The display will now show the high resolution scale weight. While the scale weight is display, you can make adjustments to the previously displayed load cell or load cell pair.

#### On the 205;

- A. Press the **ASTERISK/UP ARROW** key to make a fine adjustment in positive direction.
- B. Press the **UNITS/LEFT ARROW** key to make a fine adjustment in negative direction.
- C. Press the **ZERO** key to zero the scale when empty if needed.

#### On the 210 or 215;

- A. Press the **8** key to make a coarse adjustment in positive direction.
- B. Press the **2** key to make a coarse adjustment in negative direction.
- C. Press the **6** key to make a fine adjustment in positive direction.
- D. Press the **4** key to make a fine adjustment in negative direction.
- E. Press the **ZERO** key to zero the scale when empty if needed.

Pressing the **ENTER** key while the weight is displayed will advance the adjustment menu to the next load cell or load cell pair.

If doing single cell adjustment, the order will follow that of the SmartCal® ordering as illustrated below.

If doing dual cell adjustment, ordering is numerical (“cell 03” would be displayed next if doing single cell adjustment and “03\_\_04” would be displayed next if doing dual cell adjustments).

### SmartCal® Load Cell and Load Placement

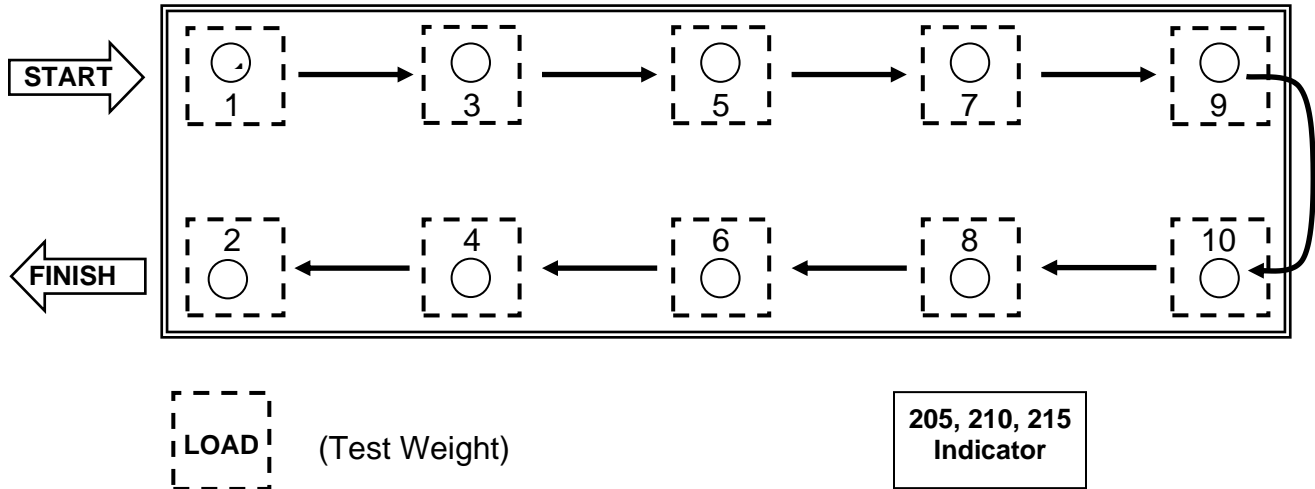

**NOTE:** For optimum performance, the test weights must be concentrated over the load cell as much as is safely possible.

Pressing the **ENTER** key again will display the high resolution weight again. Now the cell or cells that can be adjusted would be cell 3 if doing single cell or 3 and 4 if doing dual cell.

1. Position the test weight over that cell or cells before making adjustments as described above.
2. Repeat these steps until all cells are adjusted as needed.
3. Press the CAL button at any time to exit this menu.

## USING 225

1. Hold the shift key and press the red square in the middle of the arrows to enter the setup menu.
2. Enter Calibration and setup.
3. Enter the number of scales from 1-3.
4. Go to SETUP MENU #2 then enter Setup Scale 1.
5. Change the TYPE= to SNAP-4.
6. Go to SCALE 1 SETUP MENU #3 and change the load cells to 4 and enter the radio's address for address 1.
7. Enter the pair scale function and wait for the indicator to show paired. If it fails please check the address and make sure the SNAP-4R is plugged in.
8. Enter calibration for scale 1.



**At this point, a decision must be made as to what type of calibration to perform. The 225-Snap system allows three optional methods for scale calibration: SMARTCAL® (recommended); CELL OUTPUT; or DUAL POINT as described below. DUAL POINT also has several modes within this method (see CALIBRATION METHODS in the 225 Weight Indicator Installation and Technical Manual, 8200-M538-O1).**

### SMARTCAL®

SmartCal is the most precise method of calibration and is unique to the 225-Snap system. SmartCal requires that a calibrated load be placed over each load cell of the scale platform only once. In this method, the indicator will be able to derive calibration constants which will be used to combine information from each load cell into scale weight. To use this method, the scale must have 2 or more load cells.

From the SCALE 1 SETUP MENU #2 select 10. CALIBRATE by pressing the **1, 0** key, then the **ENTER** key.

From the SCALE 1 CALIBRATION MENU #2 select 10. CALIB by pressing the **1, 0** key, then the **ENTER** key.

At the SMART CAL= XXX prompt, YES must be selected, then proceed to the SMART CAL=YES section.

## CELL OUTPUT

This method of calibration requires the operator to enter in cell output for each load cell and then apply a test load to the scale. The indicator calculates the remaining calibration constants. To use this method, the scale must have 2 or more load cells.

From the **SCALE 1 SETUP MENU #2** select  
**10. CALIBRATE** by pressing the **1, 0** key, then the **ENTER** key.

From the **SCALE 1 CALIBRATION MENU #2** select  
**10. CALIBRATE** by pressing the **1, 0** key, then the **ENTER** key.

At the **SMART CAL= XXX** select **NO**. At the **CELL OUTPUT= XXX**, select **YES**. The display will show the **CELL 1**  
**mV/V=X.XXXXX** prompt. Proceed to the **CELL OUTPUT** section.

## DUAL-POINT

This is a standard calibration method requiring one weight, an empty scale and has one conversion factor. This method uses two calibration points (**CAL WT 1** and **CAL WT 2**) to establish a zero (no load) calibration value and to span the indicator. The two points correspond to zero weight and the test load or test weight and can be applied in any order.

## 10. CALIBRATE

With the **SCALE X SETUP MENU #2** displayed, press the **1, 0**, key and then the **ENTER** key to proceed to **SCALE X CALIBRATION MENU**. The calibration procedure is identical for each (1, 2, and 3) scale in a multi-scale configuration.

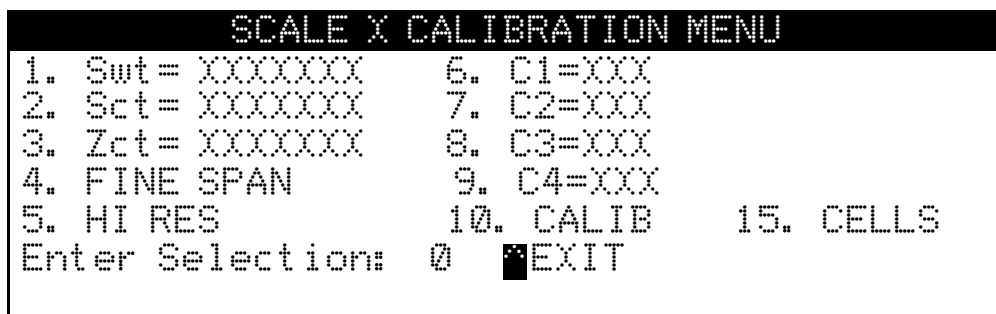

### ITEMS 1. through 9.

After calibration is complete, refer to the **CALIBRATION AND SETUP** section of the **225 Weight Indicator Installation and Technical Manual, 8200-M538-O1** for items 1 – 9.

## 15. CELLS (SCALE X CELL FINE SPAN ADJUST)

After calibration is complete, adjustments to the calibration coefficient for the load cells can be accomplished by following the steps below. The scale FINE SPAN can be accessed through the 4. FINE SPAN and 5. HI RES selections from the SCALE 1 CALIBRATION MENU.

To access the SCALE X CELL FINE SPAN ADJUST, from the SCALE X CALIBRATION MENU press 1, 5, ENTER. Up to eight cells are displayed at one time.

```

SCALE X CELL FINE SPAN ADJUST
1 XXXXXX XX.XXXX 5 XXXXXX XX.XXXX
2 XXXXXX XX.XXXX 6 XXXXXX XX.XXXX
3 XXXXXX XX.XXXX 7 XXXXXX XX.XXXX
4 XXXXXX XX.XXXX 8 XXXXXX XX.XXXX
ADJ=  XXXXX.X ^FINE UP vFINE DOWN
CELL: X  ESC EXIT <CRSE UP >CRSE DOWN

```

Single or paired load cells can be adjusted at a time. The selected load cell(s) will be highlighted.

### SINGLE CELL SELECTION

The cell number is followed by the cell total weight and the millivolt reading for that cell. ADJ= XXXXX.X is the total scale weight minus the dead load. CELL: X is the cell number selected for adjustment.

To select a different cell, key in the desired load cell number and press the **ENTER** key. The selected load cell will be highlighted.

**Eight cells can be displayed on the display at one time. If the scale has more than eight load cells, the higher numbered cells will be displayed when a number greater than 8 is entered.**

### PAIRED CELL SELECTION

To adjust two cells simultaneously, key in the first load cell number and press the **±** key. Next, key in the second load cell number and press the **ENTER** key. The selected load cells will be highlighted. The amount of adjustment will be split evenly between the two selected load cells.

## CALIBRATION COEFFICIENT ADJUSTMENT

To make coarse adjustments in the calibration coefficient for the load cell, press the **CRSE UP** or **CRSE DOWN** navigation keys. To make fine adjustments in the calibration constant for the load cell, press the **FINE UP** or **FINE DOWN** navigation keys.

To zero the scale, press the **ZERO** key.

To return to the `SCALE X CALIBRATION MENU` display, press the **ESC** key.

### 10. CALIB

From the `SCALE X CALIBRATION MENU`, press **1, 0, ENTER** to proceed to the `SMART CAL=YES` prompt.





# SMART CAL=YES

## SMARTCAL®

During SmartCal, the indicator will prompt for the test load to be applied over a particular load cell. The order will be the odd numbered cells first, followed by even numbered cells, in reverse order. For example, on an eight load cell scale, the order would be cell 1, cell 3, cell 5, cell 7, cell 8, cell 6, cell 4, cell 2. This order is used so that calibration can be done using a test cart with a minimal amount of maneuvering required. Refer to the illustration below.

### SmartCal® Load Cell and Load Placement

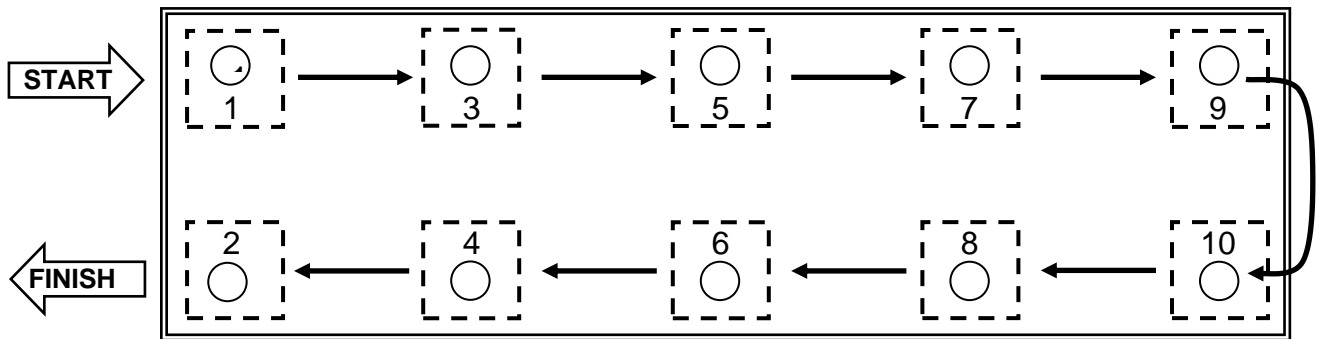

**NOTE:** For optimum performance, the test weights must be concentrated over the load cell as much as is safely possible.

To begin SmartCal, press the **YES** key and the **ENTER** key. The display will show:

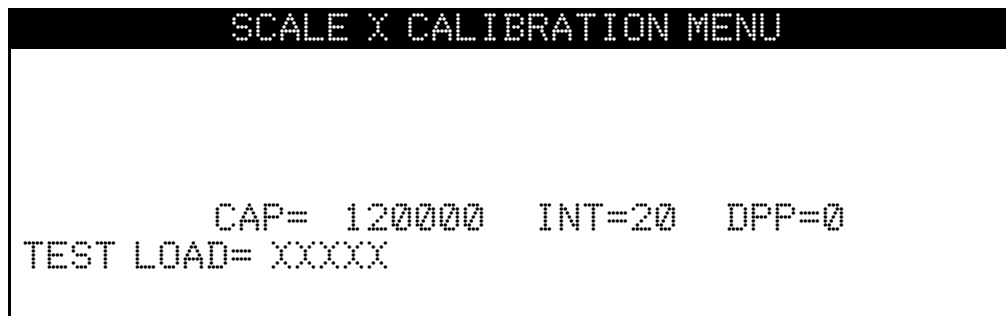

where **XXXXX** is the test load value. Key in the value of the test load and press the **ENTER** key. The display will show:

```
SCALE X CALIBRATION MENU

TEST LOAD= 10000

CAP= 120000 INT=20 DPP=0

WHEN SCALE IS EMPTY, PRESS ENTER
```

Make certain that the scale platform is empty and press the **ENTER** key. **CALIBRATING. . .** will be displayed as the indicator gathers information from the SNAP-4R. The display will then show:

```
SCALE X CALIBRATION MENU

TEST LOAD= 10000

CAP= 120000 INT=20 DPP=0

PLACE WEIGHT ON CELL 1 + PRESS ENTER
```

Concentrate the test load over cell 1 and press the **ENTER** key. **CALIBRATING. . .** will be displayed as the indicator gathers information from the SNAP-4R. Then, the display will show:

```
SCALE X CALIBRATION MENU

TEST LOAD= 10000

CAP= 120000 INT=20 DPP=0

PLACE WEIGHT ON CELL 3 + PRESS ENTER
```

Repeat the above process, moving the load to the next load cell position when prompted by the indicator.

When the test load has been applied to the last load cell, information gathered from the SNAP-4R and the **SCALE 1 CALIBRATION MENU** is displayed, the scale calibration is complete.

## CELL OUTPUT

With this method of calibration, the output rating for each load cell of the scale (which should be available from the documentation that came with the cell) is entered into the weight indicator. This information will be used to adjust the readings from each load cell so that the value of a given load will be independent of the position of the load on the scale platform.

From the `SCALE 1 CALIBRATION MENU #2` select `10. CALIBRATE` by pressing the `1, 0` key, then the **ENTER** key.

At the `SMART CAL= XXX` select `NO`. The display will show `CELL OUTPUT= XXX`.

At the `CELL IUTPUT= XXX` select `YES`.  
The display will show the `CELL 1 mV/V=X. XXXXX` prompt.

```

SCALE X SETUP MENU #3
CELL 1 mV/V=X. XXXXX
  
```

At the `CELL 1 mV/V=X. XXXXX` prompt, key in the cell output for cell 1 from the documentation that came with the load cell. If the cell output is not known, key in `2. 00000`. Press the **ENTER** key.

Repeat the for each load cell of the scale.

After all of the load cell information has been entered, the display will change to the `SCALE X CALIBRATION MENU`.

```

SCALE X CALIBRATION MENU
CAL 1= 0 CAP= 120000 INT=20 DPP=0
  
```

## STANDARD CALIBRATION MODES

The 225 indicator has seven modes that can be used to perform calibration. Four of the modes require a test load (weight), one requires the scale to be empty (and at zero) and the last two use parameter values or the calibration “C” numbers from a previous calibration. The calibration modes are as follows:

### 1. Dual-Point with Zero (First Zero)

This is a standard calibration method requiring one weight, an empty scale and has one conversion factor. This method uses two calibration points (CAL 1= and CAL 2=) to establish a zero (no load) calibration value and to span the indicator. The two points correspond to zero weight and test load (weight) and can be applied in any order. This method should be used for first-time calibration and complete recalibration.

### 2. Dual-Point without Zero (False Zero)

This calibration method requires one test weight and establishes a new conversion factor only. It is used to establish a false (temporary zero) zero without affecting the zero calibration value stored during the last calibration. This is particularly useful in tank weighing applications, where it may be impractical or impossible to completely empty the tank. This method uses two calibration points, CAL 1= and CAL 2=. The value of the test load (weight) is entered when CAL 1= is displayed and then the **NET/GROSS** key pressed when CAL 2= is displayed

### 3. Single-Point for Span Only (Last Zero)

This calibration method requires one test weight, the scale at zero and establishes a new conversion factor (span) without affecting the zero calibration value stored during the last calibration. This minimizes placing and removing test loads (weights) and is especially useful when checking high capacity scales. This method uses two calibration points, CAL 1= and CAL 2=. The value of the test load (weight) is entered when CAL 1= is displayed and then the **ZERO** key pressed when CAL 2= is displayed.

#### 4. Single-Point for Zero Only (Only Zero)

This calibration method requires no test weight, an empty scale and establishes a new zero without affecting the conversion factor (span). This is useful to regain the full range of zero limit when the dead load of the scale has changed. This would occur for example, if a guard rail has been added to the scale platform. This method uses two calibration points, CAL 1= and CAL 2=. The **ENTER** key is pressed when CAL 1= is displayed and then the **ZERO** key pressed when CAL 2= is displayed.

#### 5. Calibration Parameters (Swt, Zct and Sct)

The calibration parameters represent the test load weight Swt = (Span Weight) and the analog to digital readings at zero Zct = (Zero Count) and test load Sct = (Span Count). These values are established when the scale is calibrated. They are useful when replacing an indicator (or if the need arises to re-calibrate the scale) and a test load (weights) aren't available. By entering the previously recorded parameter values, the indicator can be returned to its present calibration setting without using test load (weights).

#### 6. Calibration "C" Numbers

The calibration "C" numbers (C1=, C2=, C3= and C4=) are displayed on the SCALE 1 CALIBRATION MENU during the calibration and setup procedure. These numbers correspond to the calibration setting of the indicator. They can be used when replacing an indicator (or if the need arises to recalibrate the scale) and test load (weights) aren't available. By entering the previously recorded numbers, the indicator can be returned to its present calibration settings without using test load (weights).

## DUAL-POINT WITH ZERO (FIRST ZERO) CALIBRATION

This method of calibration can be used if the scale has 2 or more load cells and at the **SMARTCAL** and **CELL OUTPUT** prompts, **NO** is selected. *NOTE: This is the only method of calibration available with a 1 load cell scale.*

For details on the other five calibration modes, refer to the **CALIBRATION MODES** section in the **225 Weight Indicator Installation and Technical Manual, 8200-M583-O1**.

### CAL 1=0 (First Calibration Weight)

With the SCALE 1 CALIBRATION MENU displayed, press the **1** and **0** keys and then the **ENTER** key. The display will change to show the settings for capacity, interval, decimal point position and CAL 1=0. This is the first of two calibration weights. It could be ZERO (no load) or the TEST load (weight).

1. If the first calibration weight is to be ZERO (no load), press the **ENTER** key. The display will flash CALIBRATING. . . for a few seconds and then change to show CAL 2=.
2. If the first calibration weight is to be the TEST load (weight), place the weights on the scale.
3. Using the numeric keys, enter the value of the TEST load (weight) and then press the **ENTER** key.
4. The display will flash CALIBRATING. . . for a few seconds and then change to show CAL 2=. XXXXXXXX

### CAL 2=XXXXXXXX (Second Calibration Weight)

The display will show CAL 2=XXXXXXXX. This is the second of two calibration weights. It could be ZERO (no load) or the TEST load (weight).

1. If the second calibration weight is to be ZERO (no load), press the **0** key and then the **ENTER** key. The display will flash CALIBRATING. . . for a few seconds and then change to show the SCALE 1 CALIBRATION MENU.

# SNAP-4, -8, -12, -3X4 (-10), -16, -4X4, SETUP

## USING 205, 210 OR 215

Use the \* key on a 205 to scroll through numbers and letters for addresses and the **UNITS** key to move the cursor. Refer to the illustration below to show where the letters are on a 210 or 215 for entering in addresses for SNAP-4, -8, -12, 3X4 (-10), -16 and -4x4 scales.

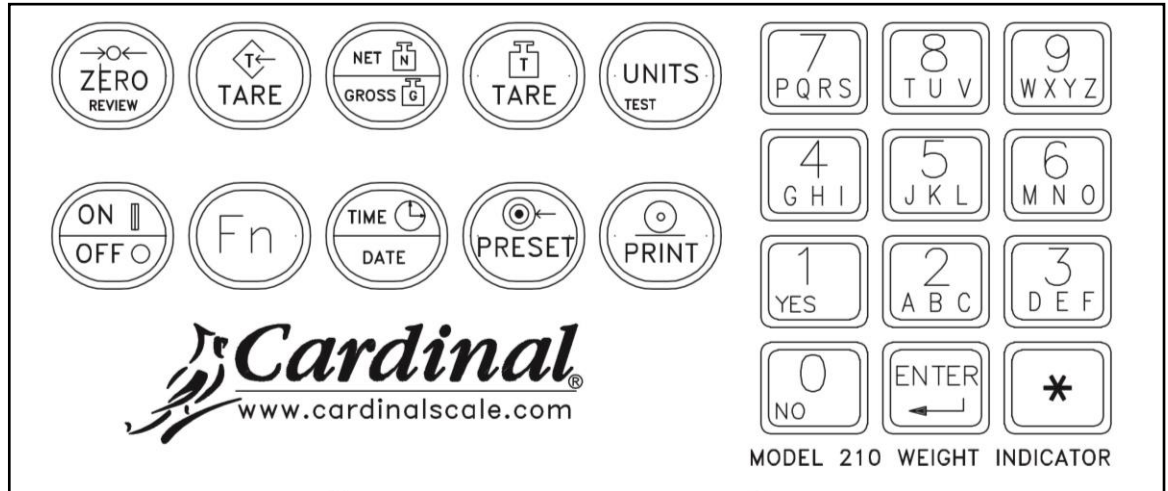

### (Updated Keypad – 205/210 with onboard USB)

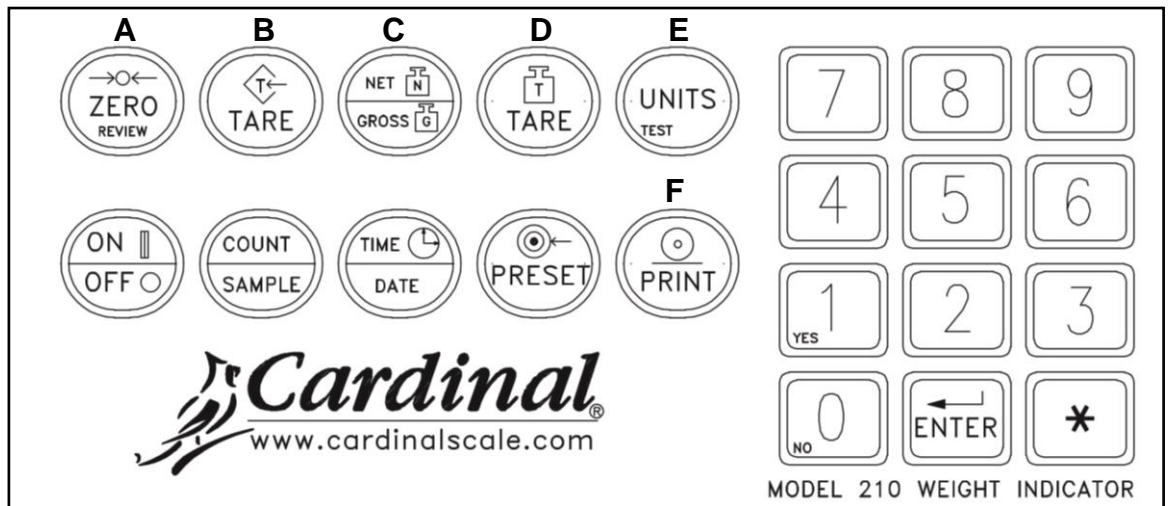

### (Legacy Keypad – 205/210/215)

**NOTE:** This section is written assuming you have a working 2XX-SNAP inserted in the indicator.

Press the cal button until the *R-d* prompt and press enter. The following is a description of the applicable prompts:

- SCLSrC* This prompt is asking if you are using a 4 Cell SNAP system or a 1 Cell SNAP system. Enter a 4 for a 4 Cell SNAP.
- CELLS:* This prompt is asking how many load cells are being used total for all scales or network of scales. This can be a number from 1-16.
- Addr 1:* This is asking for the address of the radio inside the SNAP-RF with the jumpers in the SCALE #1 position. The indicator will divide the number of load cells by 4 and ask for that many addresses. e.g., 12 load cells must have 3 addresses. 7 load cells must have 2 addresses. The actual address will be on the Radio in the SNAP-RF. e.g., If you have 1 scale with 8 load cells you will be asked for *Addr 1:* and *Addr 2:*. The one address that is on the radio inside the SNAP-RF needs to be entered in both prompts. If you have 2 scales with 8 load cells for a total of 16 load cells you will be asked for *Addr 1:* through *Addr 4:*. The address on the radio inside SNAP-RF that is jumpered for SCALE #1 will need to be entered for *Addr 1:* and *Addr 2:*. The address on the radio inside SNAP-RF that is jumpered for SCALE #2 will need to be entered for *Addr 3:* and *Addr 4:*.
- dFlt:* Same as in the 200 series manual
- Sr:* This is the sample rate of the analog section. This number can be set from 1 to 20.
- UnS:* Same as in the 200 series manual.
- SC:* Same as in the 200 series manual.

The screen will show *-bUSy-* then flash *PR rEd*. If indicator shows failed it will return to the prompt that had failed. Check to make sure address is correct.

- SNPCAL* 0 is for no CAL. 1 is for Smart Cal and 2 is for 2-point cal.
- tEstLd* Enter the weight of the test load.
- UnLoAd* Unload the scale and press enter.
- LoAd* Load the scale. If using Smart Cal, *LoAd* will change to *LoAd 1* and will increment for each load cell. You will need to load each individual load cell following the on screen prompts.
- SUCCESS* This will flash on the screen for a short while telling you that the scale has been calibrated successfully.



## MAKING LOAD CELL ADJUSTMENTS USING 205, 210 OR 215

### CELL ADJUST (*cELAdj*)

This prompt will immediately follow *SnPCAL* if 0 is selected. It will also be the next prompt displayed immediately following a calibration. It will allow you to “tweak” the weight of individual or pairs of load cells up or down.

*cELAdj*            0 = Don't Adjust Cells (skips prompt)  
                          1 = Single Load Cell Adjustment Menu  
                          2 = Dual Load Cell Adjustment Menu

To access this menu;

1. Go to the CAL section of SETUP.
2. Press the **ENTER** key to step past *SnPCAL*.
3. Enter 1 or 2 at the *cELAdj* prompt.
4. The indicator will display the cell or cell pair that can be adjusted.

1 = *CELL01* (cell 01)                      2 = *01\_02* (01\_02)

5. Position the test weight on displayed cell or cell pair and then press the **ENTER** key.
6. The display will now show the high resolution scale weight. While the scale weight is display, you can make adjustments to the previously displayed load cell or load cell pair.

#### On the 205;

- A. Press the **ASTERISK/UP ARROW** key to make a fine adjustment in positive direction.
- B. Press the **UNITS/LEFT ARROW** key to make a fine adjustment in negative direction.
- C. Press the **ZERO** key to zero the scale when empty if needed.

#### On the 210 or 215;

- A. Press the **8** key to make a coarse adjustment in positive direction.
- B. Press the **2** key to make a coarse adjustment in negative direction.
- C. Press the **6** key to make a fine adjustment in positive direction.
- D. Press the **4** key to make a fine adjustment in negative direction.
- E. Press the **ZERO** key to zero the scale when empty if needed.

Pressing the **ENTER** key while the weight is displayed will advance the adjustment menu to the next load cell or load cell pair.

If doing single cell adjustment, the order will follow that of the SmartCal® ordering as illustrated below.

If doing dual cell adjustment, ordering is numerical (“cell 03” would be displayed next if doing single cell adjustment and “03\_\_04” would be displayed next if doing dual cell adjustments).

### SmartCal® Load Cell and Load Placement

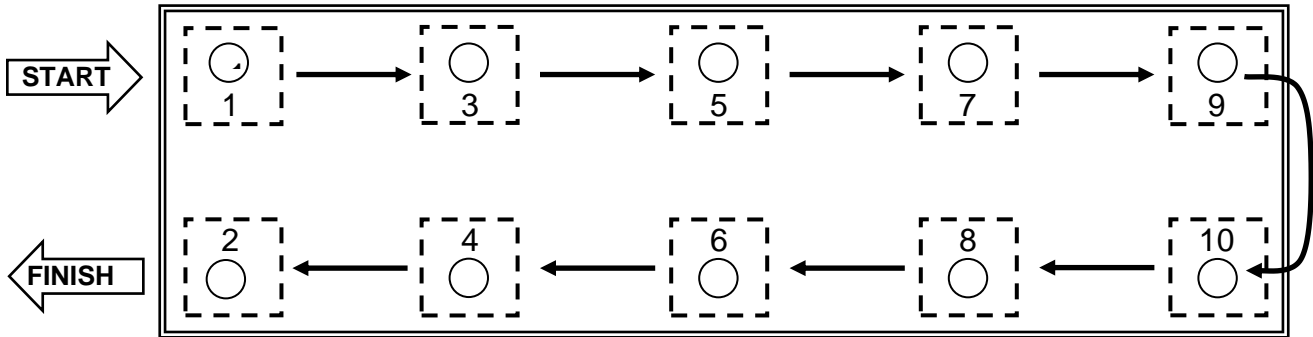

(Test Weight)

205, 210, 215  
Indicator



**NOTE:** For optimum performance, the test weights must be concentrated over the load cell as much as is safely possible.

Pressing the **ENTER** key again will display the high resolution weight again. Now the cell or cells that can be adjusted would be cell 3 if doing single cell or 3 and 4 if doing dual cell.

1. Position the test weight over that cell or cells before making adjustments as described above.
2. Repeat these steps until all cells are adjusted as needed.
3. Press the CAL button at any time to exit this menu.

## USING 225

1. Hold the shift key and press the red square in the middle of the arrows to enter the setup menu.
2. Enter Calibration and setup.
3. Enter the number of scales from 1-3.
4. Go to SETUP MENU #2 then enter Setup Scale 1.
5. Change the TYPE= to SNAP-4.
6. Go to SCALE 1 SETUP MENU #3 and change the load cells to 4 and enter the radio's address for address 1.
7. Enter the pair scale function and wait for the indicator to show paired. If it fails please check the address and make sure the SNAP-4, -8, -12, -16 or -4x4 is plugged in.
8. Enter calibration for scale 1.



**At this point, a decision must be made as to what type of calibration to perform. The 225-Snap system allows three optional methods for scale calibration: SMARTCAL® (recommended); CELL OUTPUT; or DUAL POINT as described below. DUAL POINT also has several modes within this method (see CALIBRATION METHODS in the 225 Weight Indicator Installation and Technical Manual, 8200-M538-O1).**

### SMARTCAL®

SmartCal is the most precise method of calibration and is unique to the 225-Snap system. SmartCal requires that a calibrated load be placed over each load cell of the scale platform only once. In this method, the indicator will be able to derive calibration constants which will be used to combine information from each load cell into scale weight. To use this method, the scale must have 2 or more load cells.

From the SCALE 1 SETUP MENU #2 select 10. CALIBRATE by pressing the **1, 0** key, then the **ENTER** key.

From the SCALE 1 CALIBRATION MENU #2 select 10. CALIB by pressing the **1, 0** key, then the **ENTER** key.

At the **SMART CAL= XXX** prompt, **YES** must be selected, then proceed to the **SMART CAL=YES** section.

## CELL OUTPUT

This method of calibration requires the operator to enter in cell output for each load cell and then apply a test load to the scale. The indicator calculates the remaining calibration constants. To use this method, the scale must have 2 or more load cells.

From the **SCALE 1 SETUP MENU #2** select  
**10. CALIBRATE** by pressing the **1, 0** key, then the **ENTER** key.

From the **SCALE 1 CALIBRATION MENU #2** select  
**10. CALIBRATE** by pressing the **1, 0** key, then the **ENTER** key.

At the **SMART CAL= XXX** select **NO**. At the **CELL OUTPUT= XXX**, select **YES**. The display will show the **CELL 1** **mV/V=X.XXXXX** prompt. Proceed to the **CELL OUTPUT** section.

## DUAL-POINT

This is a standard calibration method requiring one weight, an empty scale and has one conversion factor. This method uses two calibration points (**CAL WT 1** and **CAL WT 2**) to establish a zero (no load) calibration value and to span the indicator. The two points correspond to zero weight and the test load or test weight and can be applied in any order.

### 10. CALIBRATE

With the **SCALE X SETUP MENU #2** displayed, press the **1, 0**, key and then the **ENTER** key to proceed to **SCALE X CALIBRATION MENU**. The calibration procedure is identical for each (1, 2, and 3) scale in a multi-scale configuration.

```

SCALE X CALIBRATION MENU
1. Swt= XXXXXXXX      6. C1=XXX
2. Sct= XXXXXXXX      7. C2=XXX
3. Zct= XXXXXXXX      8. C3=XXX
4. FINE SPAN          9. C4=XXX
5. HI RES             10. CALIB      15. CELLS
Enter Selection: 0  [ ] EXIT
    
```

### ITEMS 1. through 9.

After calibration is complete, refer to the **CALIBRATION AND SETUP** section of the **225 Weight Indicator Installation and Technical Manual, 8200-M538-O1** for items 1 – 9.

## 15. CELLS (SCALE X CELL FINE SPAN ADJUST)

After calibration is complete, adjustments to the calibration coefficient for the load cells can be accomplished by following the steps below. The scale FINE SPAN can be accessed through the 4. FINE SPAN and 5. HI RES selections from the SCALE 1 CALIBRATION MENU.

To access the SCALE X CELL FINE SPAN ADJUST, from the SCALE X CALIBRATION MENU press 1, 5, ENTER. Up to eight cells are displayed at one time.

```

SCALE X CELL FINE SPAN ADJUST
1 XXXXXX XX.XXXX 5 XXXXXX XX.XXXX
2 XXXXXX XX.XXXX 6 XXXXXX XX.XXXX
3 XXXXXX XX.XXXX 7 XXXXXX XX.XXXX
4 XXXXXX XX.XXXX 8 XXXXXX XX.XXXX
ADJ=  XXXXX.X ^FINE UP vFINE DOWN
CELL: X  ESC EXIT <CRSE UP >CRSE DOWN

```

Single or paired load cells can be adjusted at a time. The selected load cell(s) will be highlighted.

### SINGLE CELL SELECTION

The cell number is followed by the cell total weight and the millivolt reading for that cell. ADJ= XXXXX.X is the total scale weight minus the dead load. CELL: X is the cell number selected for adjustment.

To select a different cell, key in the desired load cell number and press the **ENTER** key. The selected load cell will be highlighted.

**Eight cells can be displayed on the display at one time. If the scale has more than eight load cells, the higher numbered cells will be displayed when a number greater than 8 is entered.**

### PAIRED CELL SELECTION

To adjust two cells simultaneously, key in the first load cell number and press the **±** key. Next, key in the second load cell number and press the **ENTER** key. The selected load cells will be highlighted. The amount of adjustment will be split evenly between the two selected load cells.

## CALIBRATION COEFFICIENT ADJUSTMENT

To make coarse adjustments in the calibration coefficient for the load cell, press the **CRSE UP** or **CRSE DOWN** navigation keys. To make fine adjustments in the calibration constant for the load cell, press the **FINE UP** or **FINE DOWN** navigation keys.

To zero the scale, press the **ZERO** key.

To return to the `SCALE X CALIBRATION MENU` display, press the **ESC** key.

### 10. CALIB

From the `SCALE X CALIBRATION MENU`, press **1, 0, ENTER** to proceed to the `SMART CAL=YES` prompt.



# SMART CAL=YES

## SMARTCAL®

During SmartCal, the indicator will prompt for the test load to be applied over a particular load cell. If the scale has four or fewer load cells, the order will simply be cell 1, cell 2, and so forth up through cell 4. If the scale has more than four load cells, the order will be the odd numbered cells first, followed by even numbered cells, in reverse order. For example, on an eight load cell scale, the order would be cell 1, cell 3, cell 5, cell 7, cell 8, cell 6, cell 4, cell 2. This order is used so that calibration can be done using a test cart with a minimal amount of maneuvering required. Refer to the illustration below.

### SmartCal® Load Cell and Load Placement

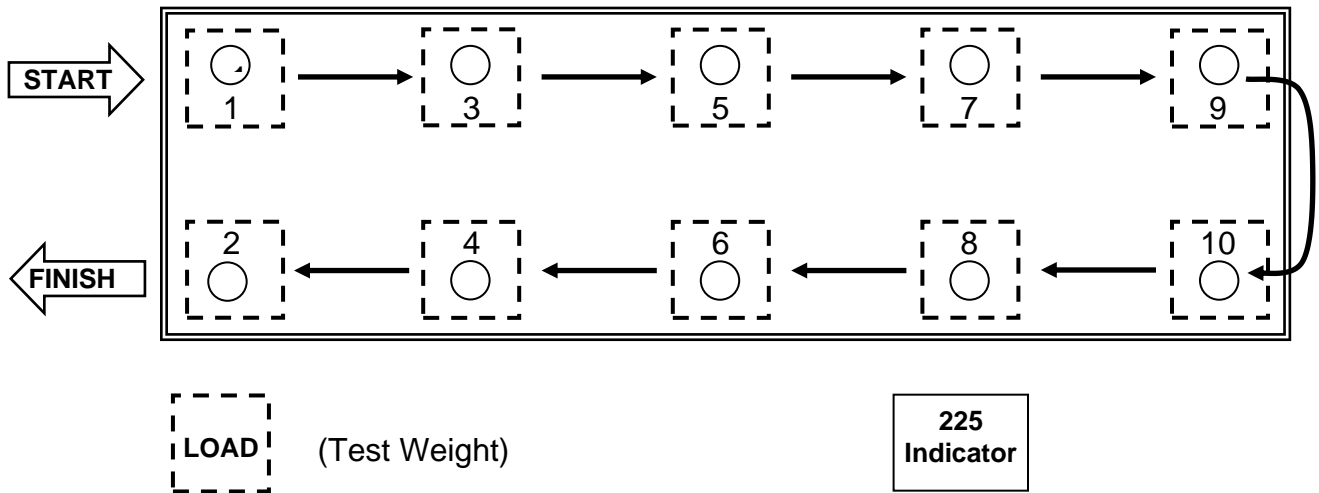

**NOTE:** For optimum performance, the test weights must be concentrated over the load cell as much as is safely possible.

To begin SmartCal, press the **YES** key and the **ENTER** key. The display will show:

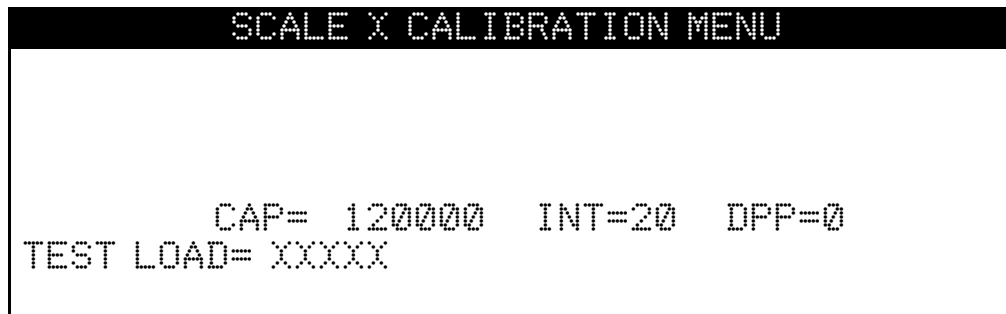

where **XXXXX** is the test load value. Key in the value of the test load and press the **ENTER** key. The display will show:

```
SCALE X CALIBRATION MENU

TEST LOAD= 10000

CAP= 120000 INT=20 DPP=0

WHEN SCALE IS EMPTY, PRESS ENTER
```

Make certain that the scale platform is empty and press the **ENTER** key. **CALIBRATING. . .** will be displayed as the indicator gathers information from the SNAP-4, -8, -12, -16 or -4x4. The display will then show:

```
SCALE X CALIBRATION MENU

TEST LOAD= 10000

CAP= 120000 INT=20 DPP=0

PLACE WEIGHT ON CELL 1 + PRESS ENTER
```

Concentrate the test load over cell 1 and press the **ENTER** key. **CALIBRATING. . .** will be displayed as the indicator gathers information from the SNAP-4, -8, -12, -16 or -4x4. Then, the display will show:

```
SCALE X CALIBRATION MENU

TEST LOAD= 10000

CAP= 120000 INT=20 DPP=0

PLACE WEIGHT ON CELL 3 + PRESS ENTER
```

Repeat the above process, moving the load to the next load cell position when prompted by the indicator.

When the test load has been applied to the last load cell, information gathered from the SNAP-4, -8, -12, -16 or -4x4 and the **SCALE 1 CALIBRATION MENU** is displayed, the scale calibration is complete.



## CELL OUTPUT

With this method of calibration, the output rating for each load cell of the scale (which should be available from the documentation that came with the cell) is entered into the weight indicator. This information will be used to adjust the readings from each load cell so that the value of a given load will be independent of the position of the load on the scale platform.

From the `SCALE 1 CALIBRATION MENU #2` select `10. CALIBRATE` by pressing the `1, 0` key, then the **ENTER** key.

At the `SMART CAL= XXX` select `NO`. The display will show `CELL OUTPUT= XXX`.

At the `CELL IUTPUT= XXX` select `YES`.  
The display will show the `CELL 1 mV/V=X.XXXXX` prompt.

```

SCALE X SETUP MENU #3
CELL 1 mV/V=X.XXXXX

```

At the `CELL 1 mV/V=X.XXXXX` prompt, key in the cell output for cell 1 from the documentation that came with the load cell. If the cell output is not known, key in `2. 00000`. Press the **ENTER** key.

Repeat the for each load cell of the scale.

After all of the load cell information has been entered, the display will change to the `SCALE X CALIBRATION MENU`.

```

SCALE X CALIBRATION MENU
CAL 1= 0 CAP= 120000 INT=20 DPP=0

```

## STANDARD CALIBRATION MODES

The 225 indicator has seven modes that can be used to perform calibration. Four of the modes require a test load (weight), one requires the scale to be empty (and at zero) and the last two use parameter values or the calibration “C” numbers from a previous calibration. The calibration modes are as follows:

### 1. Dual-Point with Zero (First Zero)

This is a standard calibration method requiring one weight, an empty scale and has one conversion factor. This method uses two calibration points (CAL 1= and CAL 2=) to establish a zero (no load) calibration value and to span the indicator. The two points correspond to zero weight and test load (weight) and can be applied in any order. This method should be used for first-time calibration and complete recalibration.

### 2. Dual-Point without Zero (False Zero)

This calibration method requires one test weight and establishes a new conversion factor only. It is used to establish a false (temporary zero) zero without affecting the zero calibration value stored during the last calibration. This is particularly useful in tank weighing applications, where it may be impractical or impossible to completely empty the tank. This method uses two calibration points, CAL 1= and CAL 2=. The value of the test load (weight) is entered when CAL 1= is displayed and then the **NET/GROSS** key pressed when CAL 2= is displayed

### 3. Single-Point for Span Only (Last Zero)

This calibration method requires one test weight, the scale at zero and establishes a new conversion factor (span) without affecting the zero calibration value stored during the last calibration. This minimizes placing and removing test loads (weights) and is especially useful when checking high capacity scales. This method uses two calibration points, CAL 1= and CAL 2=. The value of the test load (weight) is entered when CAL 1= is displayed and then the **ZERO** key pressed when CAL 2= is displayed.

#### 4. Single-Point for Zero Only (Only Zero)

This calibration method requires no test weight, an empty scale and establishes a new zero without affecting the conversion factor (span). This is useful to regain the full range of zero limit when the dead load of the scale has changed. This would occur for example, if a guard rail has been added to the scale platform. This method uses two calibration points, CAL 1= and CAL 2=. The **ENTER** key is pressed when CAL 1= is displayed and then the **ZERO** key pressed when CAL 2= is displayed.

#### 5. Calibration Parameters (Swt, Zct and Sct)

The calibration parameters represent the test load weight Swt = (Span Weight) and the analog to digital readings at zero Zct = (Zero Count) and test load Sct = (Span Count). These values are established when the scale is calibrated. They are useful when replacing an indicator (or if the need arises to re-calibrate the scale) and a test load (weights) aren't available. By entering the previously recorded parameter values, the indicator can be returned to its present calibration setting without using test load (weights).

#### 6. Calibration "C" Numbers

The calibration "C" numbers (C1=, C2=, C3= and C4=) are displayed on the SCALE 1 CALIBRATION MENU during the calibration and setup procedure. These numbers correspond to the calibration setting of the indicator. They can be used when replacing an indicator (or if the need arises to recalibrate the scale) and test load (weights) aren't available. By entering the previously recorded numbers, the indicator can be returned to its present calibration settings without using test load (weights).

## DUAL-POINT WITH ZERO (FIRST ZERO) CALIBRATION

This method of calibration can be used if the scale has 2 or more load cells and at the **SMARTCAL** and **CELL OUTPUT** prompts, **NO** is selected. *NOTE: This is the only method of calibration available with a 1 load cell scale.*

For details on the other five calibration modes, refer to the **CALIBRATION MODES** section in the **225 Weight Indicator Installation and Technical Manual, 8200-M583-O1**.

### CAL 1=0 (First Calibration Weight)

With the SCALE 1 CALIBRATION MENU displayed, press the **1** and **0** keys and then the **ENTER** key. The display will change to show the settings for capacity, interval, decimal point position and CAL 1=0. This is the first of two calibration weights. It could be ZERO (no load) or the TEST load (weight).

5. If the first calibration weight is to be ZERO (no load), press the **ENTER** key. The display will flash CALIBRATING. . . for a few seconds and then change to show CAL 2=.
6. If the first calibration weight is to be the TEST load (weight), place the weights on the scale.
7. Using the numeric keys, enter the value of the TEST load (weight) and then press the **ENTER** key.
8. The display will flash CALIBRATING. . . for a few seconds and then change to show CAL 2=. XXXXXXXX

### CAL 2=XXXXXXXX (Second Calibration Weight)

The display will show CAL 2=XXXXXXXX. This is the second of two calibration weights. It could be ZERO (no load) or the TEST load (weight).

2. If the second calibration weight is to be ZERO (no load), press the **0** key and then the **ENTER** key. The display will flash CALIBRATING. . . for a few seconds and then change to show the SCALE 1 CALIBRATION MENU.

## 2XX-SNAP (8200-C568-0A) OPTION CARD

**IMPORTANT!** The 2XX-SNAP (8200-C568-0A) is required in any 200 series indicator to be able to use any of the SNAPSTREAM products. **NOTE:** The 205, 210 and 215 must have software revision 2.6.9 to run SNAPSTREAM software. The 2XX-SNAP can also be inserted into the option card slot of any SB500 or SB250 and make the scoreboard a wireless remote display.

### 2XX SNAP Indicator Installation

**NOTE:** Should your indicator come with the option card already installed, the following section describing mounting, does not apply. Proceed to the 2XX-SNAP SETUP section.



#### **ATTENTION! OBSERVE PRECAUTIONS FOR HANDLING ELECTROSTATIC SENSITIVE DEVICES.**

1. Make sure the power to the indicator is OFF. Unplug AC power cord.
2. Loosen the gland connector(s) where the AC power cord and any other cables enter the back panel of the indicator.
3. Remove the acorn nuts securing the back panel to the main housing.
4. Lift the back panel from the main housing, taking care not to stretch the cable and wires between the panel and main housing. Lay the back panel on the workbench next to the indicator.
5. Referring to the illustration on the next page, locate the threaded stand-off and the OPTION BOARD connector on the main board.
6. To install the option card, carefully align the option connector (pins on trace side of option card) with the OPTION BOARD connector on the indicator main board and apply even downward pressure to the end of the option card at the OPTION BOARD connector.
7. Align the hole in the option card with the threaded stand-off on the main board and using the lock washer and screw supplied with the option card, secure the card to the main board.

Antenna Connector

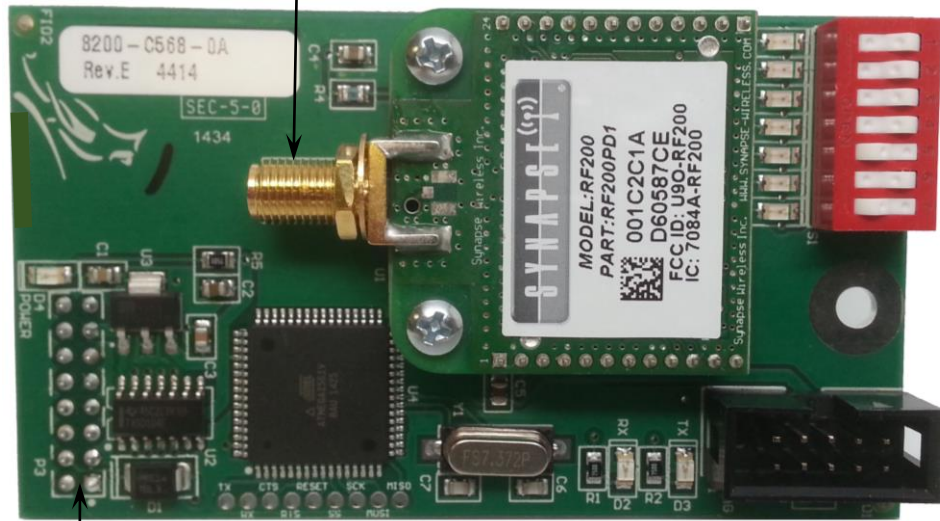

Option connector (Pins on trace side of board)

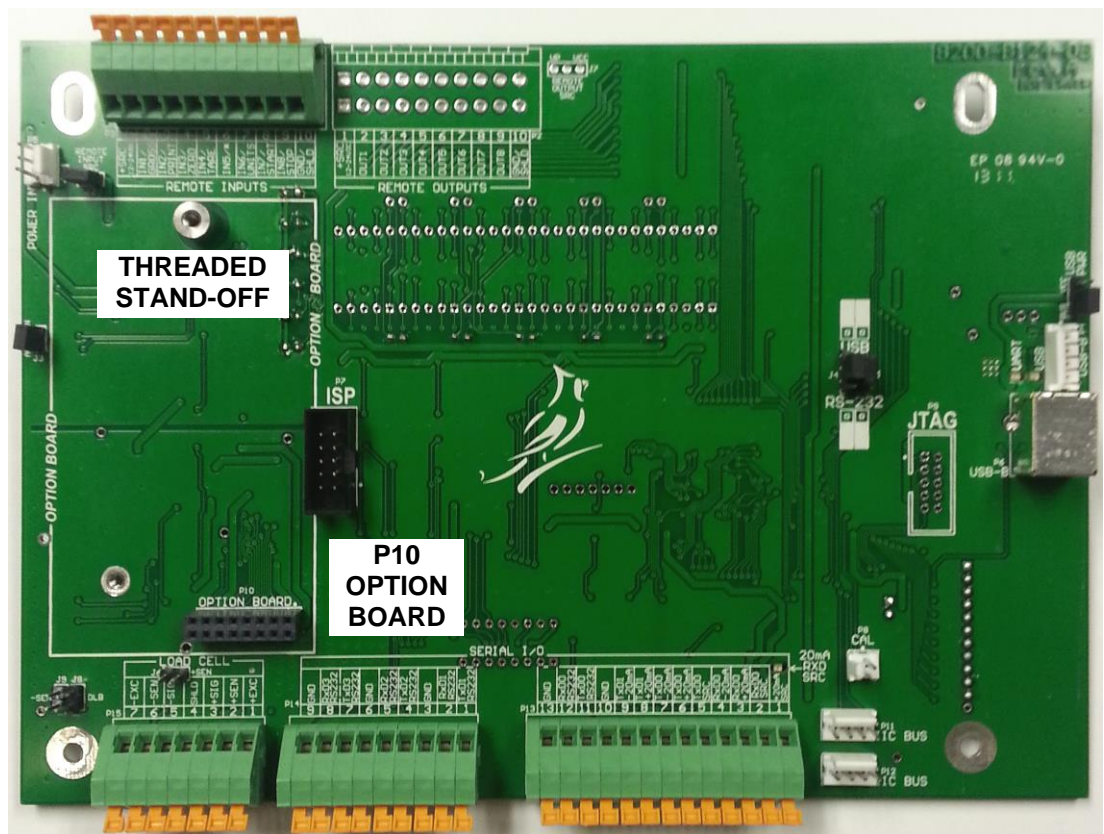

Threaded Stand-off and Option Connector

## Antenna Cable Installation

1. Loosen an unused cable gland connector for the antenna cable.
2. Remove the nut and washer from the straight end of the antenna cable and set aside.
3. From the inside of the rear panel, insert the straight end of the antenna cable through the gland connector and out of the enclosure.
4. Attach the right-angle end of the antenna cable to the antenna jack on the 2XX SNAP option card.

## 2XX-SNAP Address

The last 6 characters of the MAC address of the SYNAPSE radio on the 2XX-SNAP are its address. The following picture shows where to find these characters.



## 2XX-SNAP Radio Speed and Channel Selection

There are 2 types of SNAP radio modules and they both have the ability to change channels and transmission speeds. Currently, all of the SNAP products use the RF200 module, but you may encounter RF300 modules in the future. The RF200 modules operate at the frequency 2.4 GHz while the RF300 modules operate at 900 MHz. In order for 2 radios to communicate, the radio's channel, transmission speed, and frequency must match one another. This means that RF200 modules can ONLY talk to other RF200 modules and RF300 modules can ONLY talk to other RF300 modules.

Below is a picture of the new 2XX-SNAP with channel and speed selection. There are 4 switches to select a channel (CH1-CH4) and 2 switches to select the data transmission rate (DR1-DR2). As mentioned above, all SNAP devices that need to communicate with each other must be set to the same channel and data rate. Refer to the charts below for selecting a channel and data rate. All of the SNAP devices we sell have been and will be shipped on the default channel and data rate.





Channel Selection Chart					
Switches	CH4	CH3	CH2	CH1	
Channel 0	off	off	off	off	
Channel 1	off	off	off	<b>ON</b>	
Channel 2	off	off	<b>ON</b>	off	
Channel 3	off	off	<b>ON</b>	<b>ON</b>	
Channel 4	off	<b>ON</b>	off	off	<i>default</i>
Channel 5	off	<b>ON</b>	off	<b>ON</b>	
Channel 6	off	<b>ON</b>	<b>ON</b>	off	
Channel 7	off	<b>ON</b>	<b>ON</b>	<b>ON</b>	
Channel 8	<b>ON</b>	off	off	off	
Channel 9	<b>ON</b>	off	off	<b>ON</b>	
Channel 10	<b>ON</b>	off	<b>ON</b>	off	
Channel 11	<b>ON</b>	off	<b>ON</b>	<b>ON</b>	
Channel 12	<b>ON</b>	<b>ON</b>	off	off	
Channel 13	<b>ON</b>	<b>ON</b>	off	<b>ON</b>	
Channel 14	<b>ON</b>	<b>ON</b>	<b>ON</b>	off	
Channel 15	<b>ON</b>	<b>ON</b>	<b>ON</b>	<b>ON</b>	

**NOTE:** The LED corresponding to each switch label will be **ON** when that particular switch is **ON**.

Data Transmission Rate Chart			
Switches	DR2	DR1	
250 KHz	off	off	<i>default</i>
500 KHz	off	<b>ON</b>	
1 MHz	<b>ON</b>	off	
2 MHz	<b>ON</b>	<b>ON</b>	

**NOTE:** Faster data rates will increase the maximum sample rate the scale can attain but will also *decrease* the range or distance the radios can transmit.

## 2XX-SNAP Diagnostic LED's

The 2XX-SNAP has 2 diagnostic LED's. The following is their description.



**D3** – Blinks for every packet transmitted on the wireless network

**D2** – Blinks for every packet received on the wireless network

## Re-Installing The Rear Panel

After all terminations and connections have been made, remove the excess cable from the instrument enclosure and securely tighten each of the cable gland connectors. Do not over-tighten these connectors but make certain they are snug. **DO NOT USE TOOLS!** Finger-tighten only! Insure any unused gland connectors are plugged.

Make certain no cables or wires are exposed between the main housing and rear panel then place the rear panel onto the main housing. Secure with the acorn nuts removed earlier.



**NOTE:** Follow a diagonal pattern when tightening the acorn nuts.

## 2XX-SNAP LOCAL/REMOTE

### USING A 205, 210 OR 215

The local indicator must be setup before the remote indicators can be setup.

You can have a maximum of 1 SNAP remote indicator setup for a local indicator.

1. Press the cal button until the *R-d* prompt and then press ENTER.
2. Follow the following prompts on the remote indicator:

*SELScrC*      Enter a 2 to select the 2XX-SNAP to be a remote.

*Lr Addr*      This is the address of the radio on the 2XX-SNAP inside the local indicator. Refer to the 2XX-SNAP Address section to find the address.

*SC :*          Stable Count. Refer to the 2XX manual for description

*SR :*          Sample Rate. This is the rate at which the remote will be updated regardless of scale sample rate. Choosing a smaller sample rate than the scale sample rate is recommended.

3. After the prompts are entered the display will show *-BUSY-* until it either shows *PAIR ED* or *PAIR L*. If indicator fails check addresses and antenna connections as well as jumper setting and retry.

If a remote is being taken out of a network for any reason it will need to be unpaired from the local indicator. This must be done from the remote indicator.

1. To do this press the cal button until *OPt ion* prompt and press ENTER.
2. At the *UNPAIR* prompt, key in the address of the device you wish to unpair.
3. After unpairing the display will prompt *Another*.
4. Select *YES* if you have another device to unpair and repeat.
5. Select *no* if finished.

## USING A 225

The local indicator must be setup before the remote indicators can be setup.

You can have a maximum of 1 SNAP remote indicator setup for a local indicator.

1. Hold the **SHIFT** key and press the red square in the middle of the arrows to enter the setup menu.
2. Enter Calibration and setup.
3. Go to SETUP MENU #2 and enter the SETUP SCALE 1 menu.
4. Enter the TYPE menu and choose Type = 6 OC LR.
5. Go to SCALE 1 SETUP MENU #3 and enter item 2 and enter the address of the radio on the 2XX-SNAP inside the local indicator.
6. From the same menu choose option 6 to pair the remote indicator to the local indicator.
7. The display will show busy in lower left hand corner.
8. If the scale pairs correctly it will show Paired.
9. If the pairing fails the display will show Snap Pairing Failed!.
10. If indicator fails check addresses and antennae connections as well as jumper setting and retry.

If a remote is being taken out of a network for any reason it will need to be unpaired from the local indicator.

1. To do this hold the **SHIFT** key and press the red square in the middle of the arrows to enter the setup menu.
2. Enter Calibration and setup.
3. Go to SETUP MENU #2 and enter the SERIAL section.
4. Select SNAP LINK from the SERIAL MENU.
5. Enter the PAIRING MENU.
6. Select the remote you wish to unpair.
7. You will notice the prompt you've selected change from "Unpair" to "Pair" if the device unpairs successfully.
8. To pair the device again, simply select the same number prompt again. The prompt will change from "Pair" to "Unpair" if successful.

## **2XX-SNAP SCOREBOARD INSTALLATION**

The 2XX-SNAP can be inserted into the option card slot of any SB500 or SB250 and make the scoreboard a wireless remote display.

Insert the option card into the option card connector and use the provided cable to run the antenna out the large gland connector on the bottom of the scoreboard.

The bored gland connector will not be needed for the installation.



## 2XX-SNAP SCOREBOARD SETUP

### USING A 205, 210 OR 215

1. Press the cal switch until you get to the *Setup* prompt and press ENTER.
2. Press ENTER until the *SNAPP* prompt and then follow these prompts.

<i>SNP500</i>	Enter the number of scoreboards with 2XX-SNAP option cards from 0 to 2.
<i>Address:</i>	Enter the address on the radio of the 2XX-SNAP inside the scoreboard. Repeat for second scoreboard if needed.
<i>thresh:</i>	Enter weight to change stoplight from red to green and green to red.
<i>SNP232</i>	Refer to the SNAP-COM section of this manual for details on this prompt.

3. After the prompts are entered the display will show *-BUSY-* until it either shows *PAIR* or *FAIL*. If indicator fails check addresses and antenna connections as well as jumper setting and retry.

If a SNAP scoreboard is being taken out of a network for any reason it will need to be unpaired from the local indicator.

1. To do this press the cal button until *option* and press ENTER.
2. At the *UNPAIR* prompt, key in the address of the device you wish to unpair.
3. After unpairing the display will prompt *Another*.
4. Select *YES* if you have another device to unpair and repeat.
5. Select *no* if finished.





## USING A 225

1. Hold the **SHIFT** key and press the red square in the middle of the arrows to enter the setup menu.
2. Enter Calibration and setup.
3. Go to SETUP MENU #2 and enter the SERIAL section.
4. Select SNAP LINK from the SERIAL MENU.
5. You can have up to 2 Scoreboards using 2XX-SNAP cards in a network. Enter a 1 or a 2 in the SNAP-SB500 section.
6. You will see a new prompt of Setup SB500 1 and if you selected 2 you will also see Setup SB500 2.
7. The following are the prompts and their description in the Setup SB500 menu.

<b>ADDRESS=</b>	Enter the address on the 2XX-SNAP radio. Refer to the 2XX-SNAP Address section to find the address.
<b>SCALE=</b>	0=current selected scale. 1 to 3 selects which scale the scoreboard will be displaying. 4 will be a scoreboard for total. 5 will be for all scales and total to one 2XX-SNAP.
<b>Manual Mode=</b>	Turn ON or Off manual mode (selectable by scale #). Manual mode lets you manually control the red green light on an SB500.
<b>Thres Wt=</b>	Sets the weight threshold for the Red Green light. Simply select the scale you wish to change using the above menu, and then change the threshold. It will automatically set the threshold for that scale.

If a SNAP scoreboard is being taken out of a network for any reason it will need to be unpaired from the local indicator.

1. To do this hold the **SHIFT** key and press the red square in the middle of the arrows to enter the setup menu.
2. Enter Calibration and setup.
3. Go to SETUP MENU #2 and enter the SERIAL section.
4. Select SNAP LINK from the SERIAL MENU.
5. Enter the PAIRING MENU.
6. Select the scoreboard you wish to unpair.
7. You will notice the prompt you've selected changed from "Unpair" to "Pair" if the device unpairs successfully.
8. To pair the device again, simply select the same number prompt again. The prompt will change from "Pair" to "Unpair" if successful.

## **SNAP-COM (8300-C016-0A) / SNAP-COMIP (8300-C016-01)**

The SNAP-COM (8300-C016-0A) can be used to interface from a Snap network to a computer, printer or Cardinal Remote display. The SNAP-COM can communicate to any computer via USB, RS232 or Ethernet IP SNAP-COMIP (8300-C016-1A).

The SNAP-COM can also replace any RS232 cable in any situation. To accomplish this it will require setup using HyperTerminal and connection to a PC using the RS232 or USB port. The RS232 port allows the SNAP-COM to communicate to a printer or Cardinal remote display.

The SNAP-COM has many diagnostic LED's to show communication as well as power and error status. This allows the user to quickly diagnose problems on wireless network or wired network as well as problems internal to the PCB.

Note that the SNAP-COM must have the Cardinal drivers to use USB and the Lantronix drivers to use Ethernet.

**IMPORTANT!** Currently, VRS or a local/remote indicator can only be used on one SNAP-COM and it MUST be identified as SNAP-COM 1.

SNAP-COM 2 through 4 can only be used as printers or scoreboards.

Therefore, if it is desired to use VRS through a SNAP-COM, you will be unable to have a remote indicator using a SNAP-COM at the same time. A hard-wired com port must be used for the second node.

## SNAP-COM LED and Jumper Description



The label of each LED is clearly silkscreened on the cover of the SNAP-COM above the LED. The following is a brief description of what the LED's purposes are:

LED	Description
<b>TX-RF</b>	Turns on and off when the Wireless port on the PCB has sent data
<b>RX-RF</b>	Turns on and off when the Wireless port on the PCB has received data
<b>TX-SERIAL</b>	Turns on and off when the RS232 port on the PCB has sent data
<b>RX-SERIAL</b>	Turns on and off when the RS232 port on the PCB has received data
<b>STATUS</b>	Blinks the status of the board. For status see table below
<b>POWER</b>	12 to 24 VDC is applied to the PCB

LED Status	Description
LED Blinks twice then is off for 1 sec	EEPROM IS BAD
LED blinks 4 times then off for 1 sec	NETWORK NOT SET UP
LED is on solid	LOW VOLTAGE

The following is a description of how to use the jumpers for your different setups when using the SNAP-COM. Use the following table to set SNAP-COM number.

	ADDR0	ADDR1
<b>Com #1</b>	OFF	OFF
<b>Com #2</b>	ON	OFF
<b>Com #3</b>	OFF	ON
<b>Com #4</b>	ON	ON

When setting a SNAP-COM address make sure to remember the last 6 characters of the MAC address of the SYNAPSE radio inside the SNAP-COM box. The following picture shows where to find these characters.



The following table shows the pin-out for the DB9 connector that supplies the RS232 communication.

PIN 2	TX
PIN 3	RX
PIN 5	GND



## SNAP-COM SETUP

### USING 205, 210, 215

1. Press the cal switch until you get to the `5 0` prompt and press ENTER.
2. Press ENTER until the `SnP500` prompt and then follow these prompts:

`SnP500` Refer to the 2XX-SNAP section of this manual for details on this prompt.

`SnP232` Enter the quantity of SNAP-COM's from 0 to 4.  
NOTICE! Allowable SNAP-COM's will decrease depending on how many SNAP-COM local remotes are in network.

`Addr 1:` Enter the address on the radio of the SNAP-COM with the address jumpers set up for COM #1. Refer to the 2XX-SNAP Address section to find the address.

3. The following prompts change depending on what is entered for `PURPOS`.

`PURPOS = 0` This option sets up the SNAP-COM to be a wireless RS232 port as if it were connected to the indicator.

`PURPOS = 1` Select this if the SNAP-COM is connected to a scoreboard.

<code>TYPE:</code>	0 = SMA	4 = AnDFV	8 = SB500
	1 = SB400	5 = WI110	9 = Rin 5K
	2 = SB200	6 = Number	10 = Gedge
	3 = RICE LAKE IQ355	7 = TOLEDO	

`thres:` This prompt is only for `TYPE = 8`. Enter weight to change stoplight from red to green and green to red.

`PURPOS = 2` Select this if the SNAP-COM is connected to a Printer.

`Printer`

- 0 = default (print tabs)
- 1 = nControl slot 1
- 2 = nControl slot 2

4. You will need to repeat all prompts for each SNAP-COM module used in a network.
5. For example, if you entered a 2 for `SnP232`, once you are done with the prompts beginning with `Addr 1:` you will begin again with the prompt `Addr 2:` and will need to enter the prompts for the SNAP-COM that is jumpered for COM #2.

## SnapStream Series

If a SNAP-COM is being taken out of a network for any reason it will need to be unpaired from the local indicator.

1. To do this press the cal button until *oP t i o n* and press ENTER.
2. At the *U n P A i r* prompt, key in the address of the device you wish to unpair.
3. After unpairing, the display will prompt *A n o t h e r*.
4. Select *Y E S* if you have another device to unpair and repeat.
5. Select *n o* if finished.



## USING A 225

1. Hold the **SHIFT** key and press the red square in the middle of the arrows to enter the setup menu.
2. Enter Calibration and setup.
3. Go to SETUP MENU #2 and enter the SERIAL section.
4. Select SNAP LINK from the SERIAL MENU.
5. The following is a list of menu items and their description:

**SNAP-SB500=** Refer to the 2XX-SNAP section of this manual for details on this prompt.

**SNAP-COMS=** This is how you select how many SNAP-COM's you have in your network. You may enter 0-4. Once you have entered the # of SNAP-COM's in your network you will notice that an equal number of Setup SnapCom menus will appear.

### Setup SNAPCOM 1

The following are setup options in this menu for your selected SNAP-COM.

The next setup prompts will start with the different settings for **PURPOSE=** since the menu choices will change depending on what the purpose is.

**PURPOSE=0** This option sets up the SNAP-COM to be a wireless RS232 port as if it were connected to the indicator.

**ADDRESS=** Enter the address on the SNAP-COM radio. Refer to the 2XX-SNAP Address section to find the address.

<b>PURPOSE=1</b>	Select this if the SNAP-COM is connected to a scoreboard.
<b>TYPE=</b>	Select the type of scoreboard the SNAP-COM is connected to.
<b>SCALE=</b>	0=current selected scale. 1 to 3 selects which scale the scoreboard will be displaying. 4 will be a scoreboard for total. 5 will be for all scales and total to one SNAP-COM.
<b>ADDRESS=</b>	Enter the address on the SNAP-COM radio. Refer to the 2XX-SNAP Address section to find the address.
<b>Manual Mode=</b>	Turn ON or Off manual mode. Manual mode lets you manually control the red green light on an SB500.
<b>Thres Wt=</b>	Sets the weight threshold for the Red Green light. Each scale can have their own threshold if using option 5 in the scale menu. Simply select the scale you wish to change using the above menu, and then change the threshold. It will automatically set the threshold for that scale. Repeat process for all scales then switch to SCALE=5.
<b>PURPOSE=2</b>	Select this if the SNAP-COM is connected to a Printer.
<b>SOURCE=</b>	Selects the different print ticket format.
<b>ADDRESS=</b>	Enter the address on the SNAP-COM radio. Refer to the 2XX-SNAP Address section to find the address.

If a SNAP-COM is being taken out of a network for any reason it will need to be unpaired from the local indicator.

1. To do this hold the **SHIFT** key and press the red square in the middle of the arrows to enter the setup menu.
2. Enter Calibration and setup.
3. Go to SETUP MENU #2 and enter the SERIAL section.
4. Select SNAP LINK from the SERIAL MENU.
5. Enter the PAIRING MENU.
6. Select the COM you wish to unpair.

# SNAP-COM LOCAL/REMOTE

## USING 205, 210, OR 215

The local indicator must be setup before the remote indicators can be setup.

You can have a maximum of 1 SNAP remote indicator setup for a local indicator.



**IMPORTANT!** When using a 2XX-SNAP in the local indicator and a SNAP-COM in the *remote indicator*, the jumpers on the SNAP-COM must be set to identify the SNAP-COM as COMM 1.

When using a SNAP-COM in the local indicator and a 2XX-SNAP in the *remote indicator*, the jumpers on the SNAP-COM must be set to identify the SNAP-COM as COMM 4.

### Local/Remote SNAP-COMM Jumper Settings

Local Indicator Uses:	Remote Indicator Uses:	Set SNAP-COMM Jumpers as:
2XX-SNAP	SNAP-COMM	COMM 1
SNAP-COMM	2XX-SNAP	COMM 4

1. Press the cal button until the *R-d* prompt and then press ENTER.
2. Follow the following prompts on the remote indicator:

*SCL S r C* Enter a 3 to select the SNAP-COM to be a remote.

*L r A d r* This is the address of the radio on the 2XX-SNAP inside the local indicator. Refer to the 2XX-SNAP Address section to find the address.

*S C :* Stable Count. Refer to the 2XX manual for description

*S r :* Sample Rate. This is the rate at which the remote will be updated regardless of scale sample rate. Choosing a smaller sample rate than the scale sample rate is recommended.

3. After the prompts are entered the display will show *-BUSY-* until it either shows *P A s s e d* or *F A I L*. If indicator fails check addresses and antenna connections as well as jumper setting and retry.

If a remote is being taken out of a network for any reason it will need to be unpaired from the local indicator. This must be done from the remote indicator.

1. To do this press the cal button until *oPte ion* prompt and press ENTER.
2. At the *UnPa ir* prompt, key in the address of the device you wish to unpair.
3. After unpairing the display will prompt *Another*.
4. Select *YES* if you have another device to unpair and repeat.
5. Select *no* if finished.

## USING 225

The local indicator must be setup before the remote indicators can be setup.

You can have a maximum of 1 SNAP remote indicator setup for a local indicator.



**IMPORTANT!** When using a 2XX-SNAP in the local indicator and a SNAP-COM in the *remote indicator*, the jumpers on the SNAP-COM must be set to identify the SNAP-COM as COMM 1.

When using a SNAP-COM in the local indicator and a 2XX-SNAP in the *remote indicator*, the jumpers on the SNAP-COM must be set to identify the SNAP-COM as COMM 4.

### Local/Remote SNAP-COMM Jumper Settings

Local Indicator Uses:	Remote Indicator Uses:	Set SNAP-COMM Jumpers as:
2XX-SNAP	SNAP-COMM	COMM 1
SNAP-COMM	2XX-SNAP	COMM 4

1. Hold the **SHIFT** key and press the red square in the middle of the arrows to enter the setup menu.
2. Enter Calibration and setup.
3. Go to SETUP MENU #2 and enter the SETUP SCALE 1 menu.
4. Enter the TYPE menu and choose Type = 7 SNAP-COM LR.
5. Go to SCALE 1 SETUP MENU #3 and enter item 2 and then enter the address of the radio on the 2XX-SNAP inside the local indicator.
6. From the same menu choose option 6 to pair the remote indicator to the local indicator.
7. The display will show busy in lower left hand corner.
8. If the scale pairs correctly it will show Paired.
9. If the pairing fails the display will show Snap Pairing Failed!.
10. If indicator fails check addresses and antenna connections as well as jumper setting and retry.

## SnapStream Series

If a remote is being taken out of a network for any reason it will need to be unpaired from the local indicator.

1. To do this hold the **SHIFT** key and press the red square in the middle of the arrows to enter the setup menu.
2. Enter Calibration and setup.
3. Go to SETUP MENU #2 and enter the SERIAL section.
4. Select SNAP LINK from the SERIAL MENU.
5. Enter the PAIRING MENU.
6. Select the remote you wish to unpair.

## **SNAP-COM SCOREBOARD INSTALLATION**

The SNAP-COM can be attached to Cardinal Scoreboard that has an open RS232 port.

Use a pigtailed RS232 cable that will plug into the SNAP-COM and wire the other end into the correct port on the Scoreboard.

**The rest of the setup will be done in the indicator.**

You will need to get 12VDC to the SNAP-COM and will need a 6600-1069 RF cable to get the antenna out of the box.





## HYPERTERMINAL COMMANDS

SNAP-COM modules have 2 modes of operation, Data mode and Setup mode. On power up they are in Data mode. This mode is perfect connection to a printer or PC to communicate wirelessly to an indicator. The communications setup between the indicator and SNAP-COM will taken care of by the indicator. If you would like to remove an RS232 cable between 2 PC's or a PC and a printer or any other configuration using the SNAP-COM modules then you will need to setup the COM modules to communicate to each other using Setup mode. Setting up the SNAP-COM modules will need to be done with a PC and HyperTerminal. The RS232 or USB port can be used to accomplish this.

The following is a description of the commands for the SNAP-COM.

ATCOM+++	Toggles between Data mode and Setup mode
M??????	Enter the last 6 characters of the Radios MAC address that you wish the SNAP-COM connected to PC to talk to where the ? are. This tells the SNAP-COM plugged into PC what radio address it needs to talk to. SNAP-COM will reply with a <ETX>OK if it is entered correctly.
Sb<#>	This command sets the Baud rate. Enter a 1, 2, 3 or 4 for the # symbol. SNAP-COM will reply with a <ETX>OK if it is entered correctly. # = 1 = 9600 # = 2 = 19200 # = 3 = 38400 # = 4 = 115200
Gb	This command is to get the Baud rate from the SNAP-COM. The SNAP-COM will reply back with <0x0F><#> Definitions of # are the same as above.
SU<#>	This toggles USB on or off. The SNAP-COM will reply with a <ETX>OK if it is entered correctly. # = 1 = ON # = 0 = OFF

If there is no response from the SNAP-COM that means the command was not processed but may have been entered correctly. Try the command again or power rest the SNAP-COM and restart setup process.

If the SNAP-COM responds with IN SETUP that means it is in setup mode and needs to be switched back to Data mode for normal use or that it did not recognize the entered command and it needs to be re-entered.

**NOTE: The SNAP-COM must be returned to data mode to work!**



## SNAP-COM PC SETUP

The RS232 needs no drivers to talk to a PC. Just connect DB9 connector to serial port on PC with a RS232 cable and power on the SNAP-COM. You should not need a null modem but if your PC cannot connect to SNAP-COM that would be the first place to try trouble shooting. Open your HyperTerminal and select the COM port that the SNAP-COM is on. Here is how to set the COM ports settings.

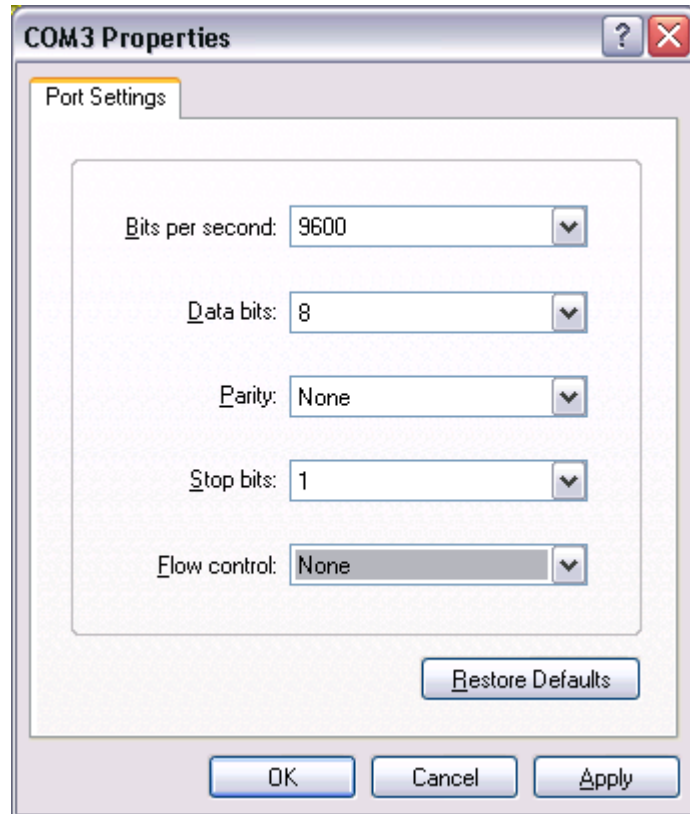

The USB and Ethernet ports will require drivers to be installed on your PC.

The USB setting can be set the same as the serial settings.

To use the Ethernet port you will need to find the IP address of the SNAP-COM. Start the Lantronix Device Installer program and click on the search icon.

You should see a window like this:

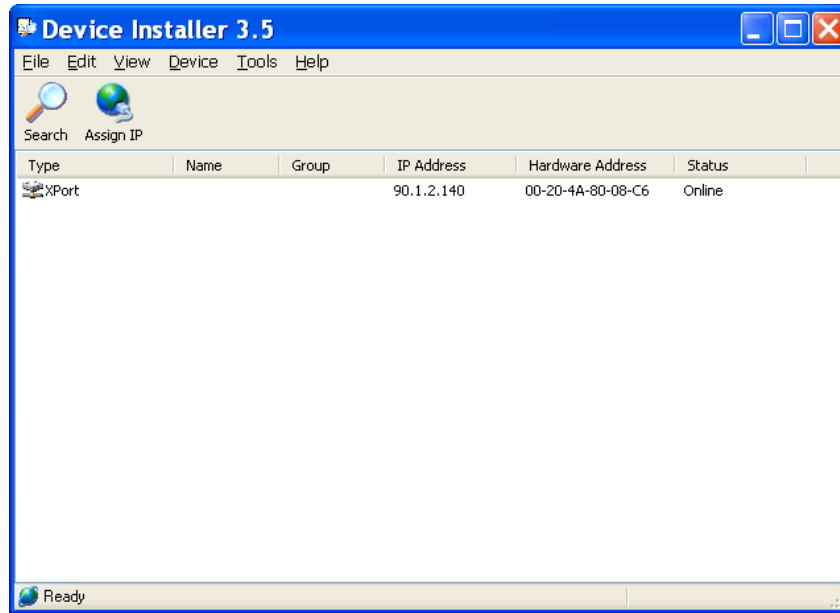

Copy the IP address and use it in the Host address section of the following window of HyperTerminal.

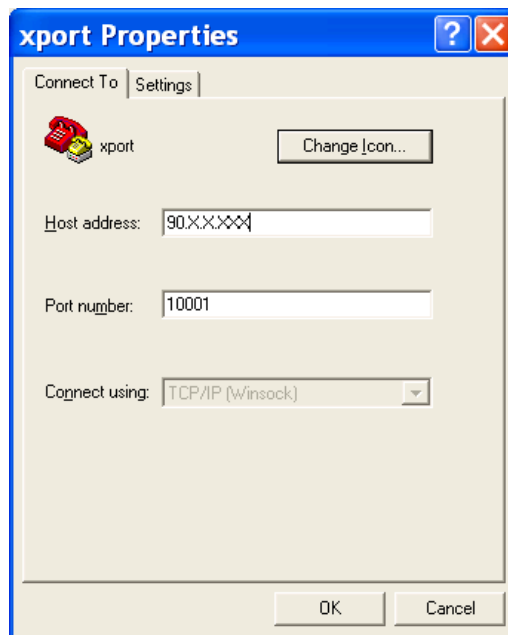

After the ports are setup you may use any of the Cardinal commands for your indicator to request weight.

## DIAGNOSTICS

### 205

1. From the weight display, press the \* and then **TEST** keys to enter diagnostics mode (if the scale is not properly displaying weight, the display will show *ERROR*).
2. Display will change to *LC 01=*.
3. Press the **ENTER** key and Load Cell 1 voltage is displayed.
4. Press the **ENTER** key and the display will show *LC 02=*.
5. Press the **ENTER** key and Load Cell 2 voltage is displayed.
6. Continue pressing **ENTER** to step through all available load cells.
7. Press the \* key to step backwards.

### 210/215

1. From the weight display press \*, '#', '#', **ENTER** to enter diagnostics mode ('#' '#' represents the load cell number. e.g., If you wanted to look at load cell number 8, you could press \*, '0' '8', **ENTER** or simply \*, 8, **ENTER**).
2. The indicator will immediately display the voltage of whichever load cell number you entered (load cell 8 voltage would be displayed from our previous example).
3. Press **ENTER** and the display will show *LC nn =* where "nn" is the next load cell number (Continuing our example, *LC 09=* would be displayed).
4. Press **ENTER** and the display will show the current voltage of that load cell (load cell 9 voltage is now displayed).
5. Continue stepping through load cells by pressing the **ENTER** key.
6. You can step backward by pressing the \* key while *LC nn=* is displayed.
7. If you press \* while a voltage is being displayed, you will exit from diagnostic mode and return to displaying weight.

## Master Clear 205, 210/215



**WARNING! This procedure will ERASE the calibration data if using a SNAP scale.**

If after checking addresses and antenna connections, the indicator continues to display *-F A I L -* (when trying to pair with the SNAP), and it is suspected that the data stored in the option card is corrupted, the following procedure will ERASE the data stored on the option card and allow you to start over:

1. Press the *cal* button until the *o P t i o n* prompt is display and then press the **ENTER** key.
2. At the *U n P A i r* prompt, key in FFFFFFFF (6 F's) and press the **ENTER** key.
3. The display will show *S u c E S S* or *-F A I L -*.

## DIAGNOSTICS

### 225

The diagnostics menu is accessible from two locations in SETUP:

SCALE X SETUP MENU #3

or

SETUP MENU #3

The menu option displayed is SNAP DIAGNOSTICS.

1. Once in the diagnostics menu, the first screen shown is the load cell voltage readings.
2. The display will show a voltage for each load cell contained in Scale 1.
3. If multiple snap scales have been setup, you can change scales by pressing the LEFT and RIGHT navigational arrow keys at any time while in the diagnostics menu.
4. The display will continuously update with the current voltage reading of the selected scale.
5. Now if you press the DOWN navigational arrow, the voltage readings will change to maximum raw count values.
6. Again, these load cell values will continuously update for the current scale.
7. Next if the operator presses the DOWN navigational arrow, the screen will change from max raw count values to dead load values.
8. These values are fixed and will not update.
9. Pressing the DOWN navigational arrow again will bring you back to load cell voltage.
10. Pressing the navigational UP arrow while the voltage menu is displayed will exit from diagnostics.
11. Pressing the UP navigational arrow from one of the other 2 menus will return you to the previous diagnostic menu.

## Master Clear 225



**WARNING! This procedure will ERASE the calibration data if using a SNAP scale.**

If after checking addresses and antenna connections, the indicator continues to display **-FAILED-** (when trying to pair with the SNAP), and it is suspected that the data stored in the option card is corrupted, the following procedure will ERASE the data stored on the option card and allow you to start over:

1. From the main SETUP MENU, key in 911 and then press the **ENTER** key.
2. The operator will be prompted to confirm if a snap scale has been previously calibrated.
3. The display will show **-SUCCESS-** or **-FAILED-**.



# TROUBLESHOOTING

## Guide to Optimum Signal Strength

While some of the items listed below can affect performance, they will not prohibit your wireless radio from functioning. If you are concerned that your wireless radio is not operating at its maximum effectiveness, this checklist may help.

### Antenna Placement

Ensure that your antennas are parallel to each other, and are positioned vertically (or point the antennas as much as possible in an upward direction).

Since antennas work best when they are essentially parallel to one another without being directly above or below each other, try to position the antennas of all your devices in the same orientation. Refer to the illustrations on page 45.

### Avoid Obstacles and Interference

There could be interference problems in your vicinity such as large metal objects, dense foliage, and other objects that prevent signal transmission or attenuation (signal loss).

Dense objects that can inhibit wireless communication include:

- Refrigerators
- Metal cabinets
- Metallic-based UV tinted windows

If your wireless signal seems weak in some spots, make sure that objects such as these are not blocking the signal's path between your devices.

Avoid placing the wireless radio near devices that may emit radio "noise," such as microwave ovens.

## **Cordless Phones**

If the performance of your wireless radio is impaired after attending to the above issues, and you have a cordless 2.4GHz phone:

- Try moving the cordless phones away from your wireless radio.
- Unplug and remove the battery from any cordless phone that operates on the 2.4GHz band (check manufacturer's information). If this fixes the problem, your phone may be interfering.

### CORRECT Antenna Placement

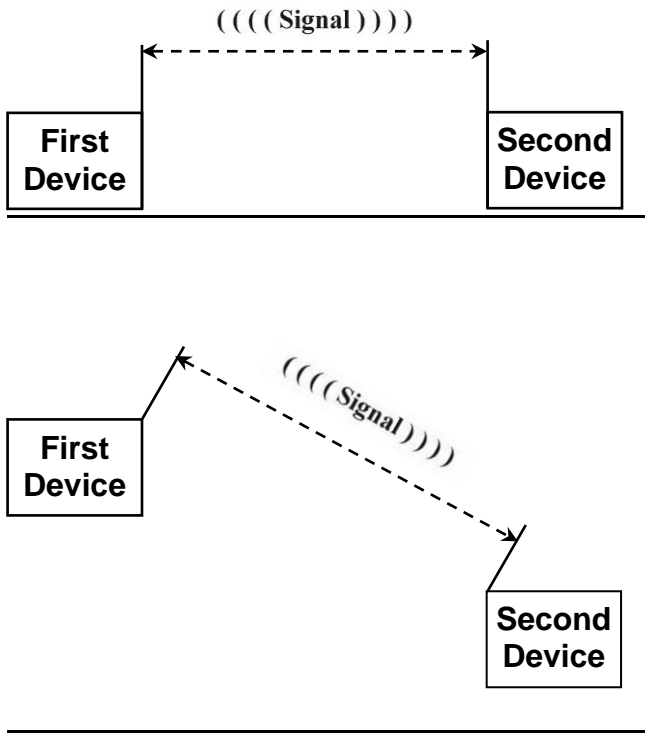

### INCORRECT Antenna Placement

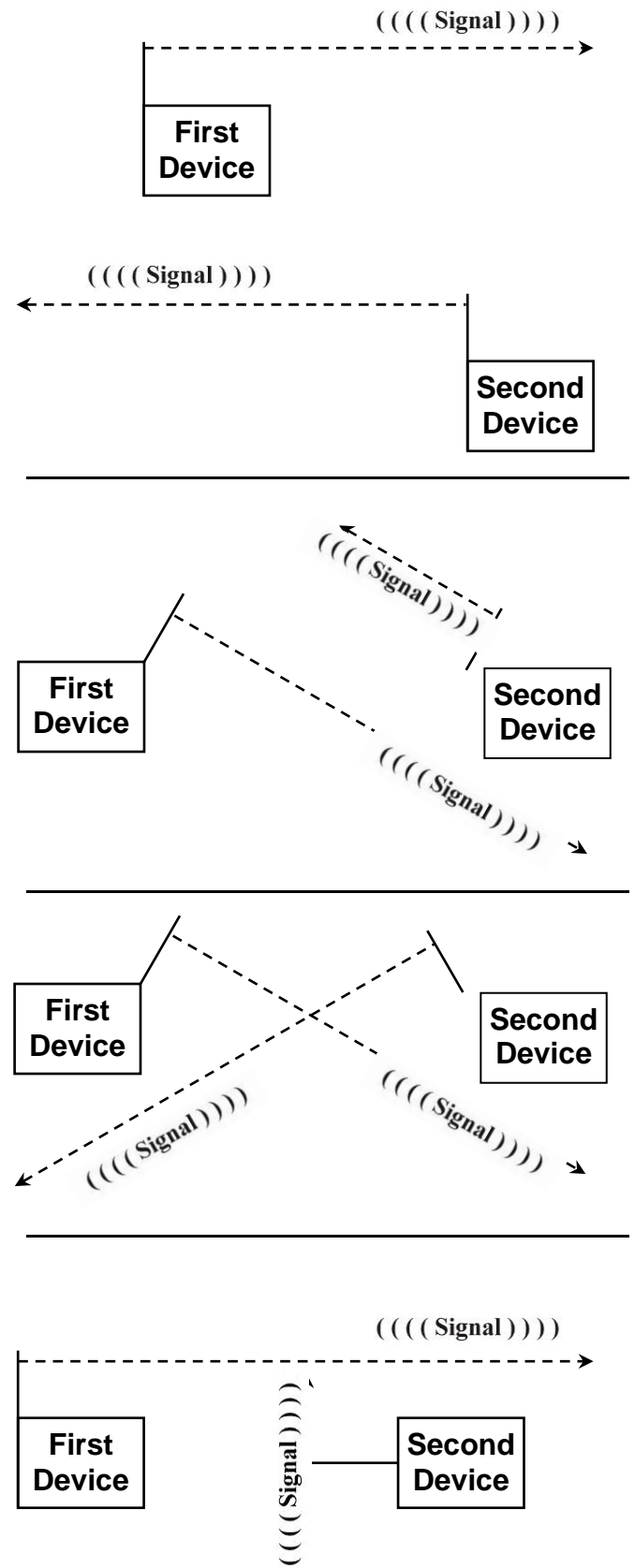



## 8300-D001-0A LED and Jumper Description

The label of each LED is clearly silkscreened on the PCB next to the LED. The following is a brief description of what the LED's purposes are.

<b>LED</b>	<b>Description</b>
<b>PWR ON</b>	- 12-24 VDC is applied to the PCB correctly
<b>232 TX</b>	- Turns on and off when the RS232 port on the PCB has sent data
<b>PWR LOW</b>	- The VDC has dropped at or below 10 V and the Analog section is off
<b>ALG1-4 ERR</b>	- The analog signal voltage for this A2D is either high, low or not connected
<b>A/D SMPL</b>	- Turns on and off for every sample from any of the A2D's
<b>SYN TX</b>	- Turns on and off when the Wireless port on the PCB has sent data

The label of each of the jumpers is clearly silkscreened on the PCB next to the jumper. The following is a brief description of what the jumpers purposes are.

<b>1-4 DLB</b>	- Dead Load Boost for that analog section
<b>ADDR0-1</b>	- Sets the address for that board if more than 1 boards are used in a network

Use the following table to set address jumpers correctly for networks with of SNAP-4 scales

<b>BOARD #</b>	<b>ADDR0</b>	<b>ADDR1</b>	<b>LOAD CELL #'s</b>
<b># 1</b>	OFF	OFF	1 – 4
<b># 2</b>	ON	OFF	5 – 8
<b># 3</b>	OFF	ON	9 – 12
<b># 4</b>	ON	ON	13 – 16

When setting up the network on the indicator these address settings directly relate to the **ADR 1**, **ADR 2** etc. prompts.



## 8300-C002-2A LED and Jumper Description

The label of each LED is clearly silkscreened on the PCB next to the LED. The following is a brief description of what the LED's purposes are.

<b>LED</b>	<b>Description</b>
<b>D1</b>	- Turns on and off when the Wireless port on the PCB has sent data
<b>D2</b>	- Turns on and off when the Wireless port on the PCB has received data
<b>D3</b>	- Turns on and off when the RS232 port on the PCB has sent data
<b>D4</b>	- Turns on and off when the RS232 port on the PCB has received data
<b>D5</b>	- Blinks the status of the board. For status table see SNAP-COM section.
<b>D6</b>	- 12-24 VDC is applied to the PCB

This board is used inside the RF box assembly which comes with a SNAP-8, SNAP-12, SNAP-16 or SNAP-4X4.

**This board is RF box specific and may not be used as a SNAP-COM!!!**

If a single SNAP-RF is being used for all SNAP-4 boards, then both ADDR0 and ADDR1 must be **OFF**.

If more than 1 SNAP-RF is communicating with a single indicator, then both ADDR0 and ADDR1 must be **ON**.

# STATEMENT OF LIMITED WARRANTY

## WARRANTY TERMS

Cardinal Scale Manufacturing Company warrants the equipment we manufacture against defects in material and workmanship. The length and terms and conditions of these warranties vary with the type of product and are summarized below:

PRODUCT TYPE	TERM	MATERIAL AND WORKMANSHIP	LIGHTNING DAMAGE See note 9	WATER DAMAGE See note 7	CORROSION See note 4	ON-SITE LABOR	LIMITATIONS AND REQUIREMENTS
<b>WEIGHT INDICATORS</b>	90 DAY REPLACEMENT ----- 1 YEAR PARTS	YES	YES	YES	YES	NO	1, 2, 3, 5, 6 A, B, C, D
<b>LOAD CELLS</b> (Excluding Hydraulic)	1 YEAR	YES	YES	YES	YES	NO	1, 2, 3, 5, 6 A, B, C, D
<b>HYDRAULIC LOAD CELLS</b> (When purchased with Guardian Vehicle Scale)	LIFE	YES	YES	YES	YES	90 DAYS	1, 5, 6, 8 A, B, C, D
<b>HYDRAULIC LOAD CELLS</b> (When purchased separately)	10 YEARS	YES	YES	YES	YES	NO	1, 5, 6, 8, 9 A, B, C, D
<b>VEHICLE SCALE</b> (Deck and Below Excl. PSC Series)	5 YEARS	YES	YES	YES	YES	90 DAYS	1, 2, 3, 5, 6 A, B, C, D, E
<b>PSC and LSC SCALE STRUCTURES</b> (Deck and Below)	3 YEARS	YES	YES	YES	YES	90 DAYS	1, 2, 3, 5, 6, 11 A, B, C, D
<b>GUARDIAN FLOOR SCALES</b>	10 YEARS	YES	YES	YES	YES	NO	1, 2, 3, 5, 6, 9, 10 A, B, C, D
<b>ALL OTHER CARDINAL PRODUCTS</b>	1 YEAR	YES	YES	YES	YES	NO	1, 2, 5, 6 A, B, C, D, E
<b>REPLACEMENT PARTS</b>	90 DAYS	YES	YES	YES	YES	NO	1, 2, 4, 5, 6 A, B, C, D
<b>IN-MOTION VEHICLE SCALES</b>	1 YEAR	YES	YES	YES	YES	90 DAYS	1, 2, 5, 6 A, B, C, D
<b>SOFTWARE</b>	90 DAYS	YES	N/A	N/A	N/A	NO	1, 6 B, C, D



Ph. (800) 441-4237  
 E-mail: cardinal@cardet.com  
 203 E. Daugherty  
 Webb City, MO 64870

06/13  
 Printed in USA  
 315-WARRANTY-CAR-K



## APPLICABLE LIMITATIONS AND REQUIREMENTS

1. This warranty applies only to the original purchaser. The warranty does not apply to equipment that has been tampered with, defaced, damaged, or had repairs or modifications not authorized by Cardinal or has had the serial number altered, defaced or removed.
2. This warranty is not applicable to equipment that has not been grounded in accordance with Cardinal's recommendations.
3. This equipment must be installed and continuously maintained by an authorized Cardinal dealer.
4. Applies only to components constructed from stainless steel.
5. This warranty does not apply to equipment damaged in transit. Claims for such damage must be made with the responsible freight carrier in accordance with freight carrier regulations.
6. Warranty term begins with date of shipment from Cardinal.
7. Only if device is rated NEMA 4 or better or IP equivalent.
8. Lifetime warranty applies to damages resulting from water, lightning, and voltage transients and applies only to the hydraulic load cell structure itself (does not include pressure transducers, rubber seals, o-rings, and associated wiring).
9. 10 Year prorated warranty on hydraulic load cells.
10. 1 Year warranty for scale structure.
11. PSC models' warranty coverage applies only to agricultural installations on farms up to 3,000 acres (LSC models not limited in this manner).
12. Load cell kits MUST be installed in accordance with Cardinal Scale instructions. Failure to follow these instructions will void the warranty.

## EXCLUSIONS

- A.) This warranty does not include replacement of consumable or expendable parts. The warranty does not apply to any item that has been damaged due to unusual wear, abuse, improper line voltage, overloading, theft, fire, water, prolonged storage or exposure while in purchaser's possession or acts of God unless otherwise stated herein.
- B.) This warranty does not apply to peripheral equipment not manufactured by Cardinal. This equipment will normally be covered by the equipment manufacturer's warranty.
- C.) This warranty sets forth the extent of our liability for breach of any warranty or deficiency in connection with the sale or use of our product. Cardinal will not be liable for consequential damages of any nature, including but not limited to loss of profit, delays or expenses, whether based on tort or contract. Cardinal reserves the right to incorporate improvements in material and design without notice and is not obligated to incorporate said improvements in equipment previously manufactured.
- D.) This warranty is in lieu of all other warranties expressed or implied including any warranty that extends beyond the description of the product including any warranty of merchantability or fitness for a particular purpose. This warranty covers only those Cardinal products installed in the forty-eight contiguous United States and Canada.
- E.) This warranty does not cover paint coatings due to the variety of environmental conditions.
- F.) Do not cut load cell cables on load cells returned for credit or warranty replacement. Cutting the cable will void the warranty.
- G.) Software is warranted only for performance of the functions listed in the software manual and/or the Cardinal proposal.
- H.) The software warranty does not cover hardware. Warranties on hardware are provided from the hardware vendor only.
- I.) The software warranty does not cover interfacing issues to non-Cardinal supplied hardware.
- J.) The software warranty does not include automatic software upgrades unless purchased separately.



Ph. (800) 441-4237  
E-mail: cardinal@cardet.com  
203 E. Daugherty  
Webb City, MO 64870

06/13  
Printed in USA  
315-WARRANTY-CAR-K



Printed in USA

8300-M052-O1 Rev C 11/14

**Cardinal Scale Mfg. Co.**

203 E. Daugherty, Webb City, MO 64870 USA

Ph: 417-673-4631 or 800-441-4237

Fax: 417-673-2153

[www.cardinalscalet.com](http://www.cardinalscalet.com)

Technical Support: 866-254-8261

E-mail: [techsupport@cardet.com](mailto:techsupport@cardet.com)