

DETECTO®

model **6495**
**WHEELCHAIR
SCALES**



Optional



Detecto
Model 6495
Wheelchair Scale
with Easy-Access Ramp



- 800 lb / 360 kg Capacity
- Optional Wi-Fi for EMR/EHR
- Sturdy Steel Construction

EFFICIENT MEASUREMENT



The 6495's MedVue® weight indicator is the clinical industry's most advanced, featuring EMR/EHR-ready serial, USB, and optional Wi-Fi connectivity, BMI calculation, yellow "quick keys" for basic weighing, and a multi-line LCD display. The scale is powered by 6 AA batteries (not included) or optional AC adapter.



- Up to 99 tares (optional) to store wheelchair weights for efficient patient weighing.
- Hold/Release key to hold a weight after leaving the scale for better patient care.
- Patient ID Barcode Scanning: Send 14-digit patient ID to the scale's MedVue® indicator for EMR/EHR records.
- Sturdy steel handrails for patient assurance and safety.



With Detecto's 6495 heavy-duty wheelchair scale, you receive digital speed and increased accuracy. The scale's ramp with non-skid surface and padded handrails ease wheelchair or standing patient weighing.

350-Degree Swivel Mounting Bracket

Enjoy freedom of movement wherever you need to position the display for the nurse or patient to easily read with the tilt-and-swivel mounting bracket.

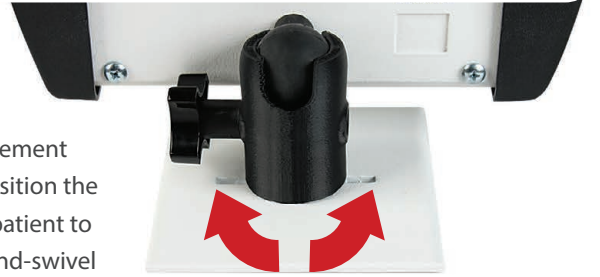

350-degree ball-pivot mount



DETECTO.
A Division of Cardinal Scale Manufacturing Co.



**Spacious
Weighing
Platform**

This heavy-duty stationary wheelchair scale features a detachable ramp for smooth entry and exit. The 6495 features a padded handrail for ambulatory patients, and Detecto's state-of-the-art MedVue® indicator allows height to be entered on the keypad for BMI calculation.

model 6495 WHEELCHAIR SCALES

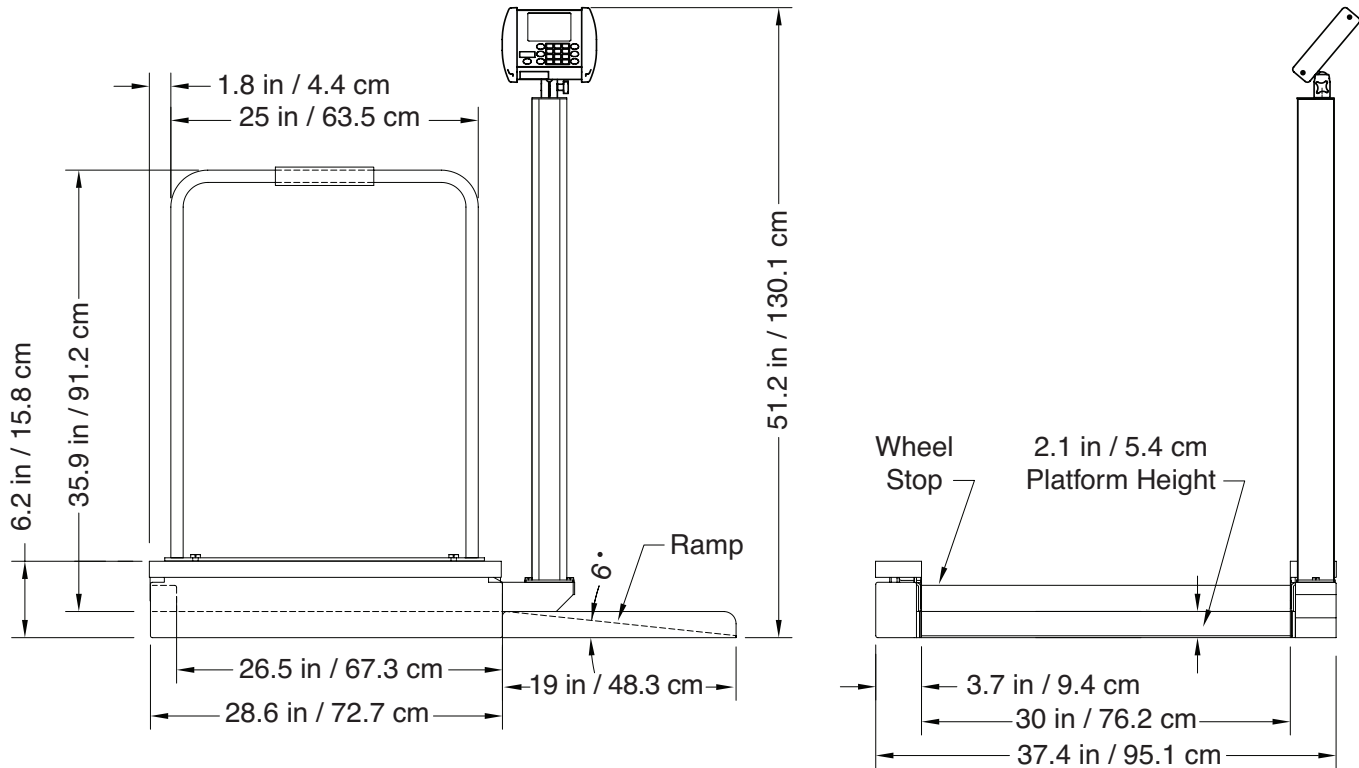

Capacity	800 lb x 0.2 lb / 360 kg x 0.1 kg
Display	Weight: 5-digit, 7-segment, 7/8 inch (22.2 mm) high LCD Height: 4-digit, 7-segment, 1/2 inch (12.7 mm) high LCD
Keypad	Membrane type with 19 keys
Connectivity Ports	RS232 serial and USB (standard), wired and Wi-Fi Ethernet (optional)
Power	6 AA cell Alkaline, Ni-Cad or NiMH batteries (not included) OR an optional 12 VDC 1.25A wall plug-in AC power adapter (Detecto part number MV1PWR)
Resolution	5,000 divisions, maximum
Operating Temperature	14° to 104° F (-10° to +40° C)
Indicator Dimensions	6.8 inch H x 7.6 inch W x 1.8 inch D (171.4 mm W x 193.8 mm H x 44.4 mm D)
Platform Dimensions	26.5 inch W x 30 inch D (673 mm W x 762 mm D)
Construction	Steel
UPC Code	809161138702
Shipping Weight	187 lb / 84.8 kg (2 boxes)

Detecto Scale reserves the right to improve, enhance, or modify features and specifications without prior notice.

DETECTO®

102 East Daugherty St., Webb City, MO 64870 USA
Toll-Free: (800) 641-2008 E-mail: detecto@cardet.com
www.Detecto.com

SOLD BY:

ISO
REGISTERED 9001