



Model 6560

Portable Wheelchair Scale

Service Manual

FCC COMPLIANCE STATEMENT

This equipment generates uses and can radiate radio frequency and if not installed and used in accordance with the instruction manual, may cause interference to radio communications. It has been tested and found to comply with the limits for a Class A computing device pursuant to Subpart J of Part 15 of FCC rules, which are designed to provide reasonable protection against such interference when operated in a commercial environment. Operation of this equipment in a residential area may cause interference in which case the user will be responsible to take whatever measures necessary to correct the interference.

You may find the booklet "How to Identify and Resolve Radio TV Interference Problems" prepared by the Federal Communications Commission helpful. It is available from the U.S. Government Printing Office, Washington, D.C. 20402. Stock No. 001-000-00315-4.

PROPER DISPOSAL

When this device reaches the end of its useful life, it must be properly disposed of. It must not be disposed of as unsorted municipal waste. Within the European Union, this device should be returned to the distributor from where it was purchased for proper disposal. This is in accordance with EU Directive 2002/96/EC. Within North America, the device should be disposed of in accordance with the local laws regarding the disposal of waste electrical and electronic equipment.

It is everyone's responsibility to help maintain the environment and to reduce the effects of hazardous substances contained in electrical and electronic equipment on human health. Please do your part by making certain that this device is properly disposed of. The symbol shown to the right indicates that this device must not be disposed of in unsorted municipal waste programs.



COPYRIGHT

All rights reserved. Reproduction or use, without expressed written permission, of editorial or pictorial content, in any manner, is prohibited. No patent liability is assumed with respect to the use of the information contained herein.

DISCLAIMER

While every precaution has been taken in the preparation of this manual, the Seller assumes no responsibility for errors or omissions. Neither is any liability assumed for damages resulting from use of the information contained herein. All instructions and diagrams have been checked for accuracy and ease of application; however, success and safety in working with tools depend to a great extent upon the individual accuracy, skill and caution. For this reason, the Seller is not able to guarantee the result of any procedure contained herein. Nor can they assume responsibility for any damage to property or injury to persons occasioned from the procedures. Persons engaging the procedures do so entirely at their own risk.

CARE AND CLEANING

Indicator

The indicator contains no user-serviceable parts and maintenance should be limited to an occasional cleaning and battery replacement as required.

General Cleaning Instructions

- Do not submerge the scale or indicator in water, pour or spray water directly on them to clean. The scale and indicator are not waterproof and covering them with water will damage them and void the warranty.
- Always remove power before cleaning.
- When cleaning, use only damp soft cloths or plastic scouring pads for cleaning cloth and a mild non-abrasive detergent.
- **DO NOT** use acetone, thinner or other volatile solvents for cleaning.
- **DO NOT** use things which will scratch the surface, such as steel pads, wire brushes and scrapers.

Powder Painted Steel Care and Cleaning

While powder painted steel is attractive and so durable that it will last many years longer than ordinary painted steel, it is desirable to clean it thoroughly on a routine basis. There are three basic things that should be remembered when cleaning powder painted steel.

1. Do not use wire brushes, abrasives, or cleaning tools such as steel pads and scrapers, which will scratch the painted surface. Instead, use soft cloths or plastic scouring pads for cleaning. Clean food equipment frequently to avoid build-up.
2. When possible, use treated water. Hard water can leave behind deposits. Soft water is much gentler on the painted steel's surface.
3. Avoid the use of acetone, thinner or other volatile solvents and abrasive type cleaners for cleaning. If required, a mild solvent such as mineral spirits can be used to remove oil, grease, tars, wax, and similar substances. Use a cloth dampened with mineral spirits and apply only to areas that are contaminated. Follow up the use of this mild solvent with detergent cleaning and rinsing.

MODEL 6560

PORTABLE WHEELCHAIR SCALE

TEST PROCEDURE

- A. Equipment Required
- B. Scale Trim Adjustment
- C. Calibration
- D. Final Test



A. Equipment Required

Scale under test

Standard Hand tools

Test Weights: Appropriate certified weights to accomplish the linearity tests

B. Scale Trim Adjustment

1. Gain access to the junction box and remove the cover.
2. Place a test weight of at least 25 percent of scale capacity on each corner, one at a time, and record each displayed weight.
3. Place test weight on the corner with the highest displayed weight and adjust appropriate trim potentiometer counterclockwise until corner reading agrees with the lowest weight reading.
4. Repeat Step No. 3 until all corners are within tolerance. For tolerance values, refer to the Linearity Check Table in the **D. Final Test** section.
5. If any trim pot reaches the end of adjustment in the CCW direction then turn all potentiometers clockwise 25 turns or until a click is heard. Now turn all potentiometers counterclockwise 1 (one) turn and repeat steps 2 - 4.
6. Turn the power off.

C. Calibration

1. To begin Calibration and Setup, make sure the MEDVUE indicator is turned on.
2. Next, looking at the front of the MEDVUE, remove the two screws from the left end cap and remove the end cap.
3. Locate the calibration switch access hole near the bottom of the side panel, and insert a small hex wrench or tool through the access hole.
4. Press and hold the calibration switch until the display changes to show SETUP in large letters at the top of the display, and SCALE in smaller letters at the bottom.
5. Release the calibration switch. You are now ready to perform calibration.
6. During setup and calibration, pressing the **PRINT/ENTER** key will cause the data displayed, to be retained and the indicator to advance to the next prompt. Change the value by entering the new data using the numeric keypad, and then pressing the **PRINT/ENTER** key.
7. Follow the prompts listed in the MEDVUE SETUP TABLE.

MEDVUE SETUP TABLE	
CAPACITY =	1000
OIML =	NO
UNITS =	2
INTERVAL =	2
dECIMAL =	1
MOTION RANGE =	2
SAMPLE RATE =	2
ZERO LIMIT =	no
POWER UP ZERO =	no
ZERO TRACKING =	3
FILTER MOdE =	2
FILTER LEVEL =	0
CALiBRATE =	YES
NUM CAL POINTS =	1
LOAdEd CAL WT =	APPLY FULL CAPACITY WEIGHT
UNLOAD	REMOVE TEST WEIGHTS
GRAVITY ENAbLE =	no
HOLd MOdE =	2
BANd =	99
LANGUAGE =	0
bACKLIGHT =	150
KEYPAdbEEP =	YES
SLEEP MOdE =	4
AUTO SHUT OFF =	2
KEY dISAbLE =	0
ENAbLE Id =	no
bARCOdE =	no
USE HEIGHT =	no
bOdY MASS IdX =	YES
HI RESOLUTION =	no
RS232 MOdE =	3
bAUd RATE =	3
PRINTER TYPE =	0
END OF PRINT =	0
USb MOdE =	1
YEAR [YYYY] =	Enter current year
MONTH [1-12] =	Enter current month
dAY [1-31] =.	Enter current day of the month
HOUR [0-23] =	Enter current hour in 24-hour format
MINUTE [0-59] =	Enter current minute
SECONd [0-59] =	Enter current second
24 HOUR TIME =	no

D. Final Test

1. Perform Corner Test using 1/4 capacity weights (positions 1-4). Use tolerances listed in the table below.
2. Perform Linearity test. Check both ascending and descending. See table below.
3. Install indicator cover.

Linearity Check Table

Applied Weight	Tolerance			WEIGHT POS
0	0			
*200 lb	199.8 lb	To	200.2 lb	1,2,3,4
400 lb	399.8 lb	To	400.2 lb	1+4 Then 2+3
500 lb	499.8 lb-	To	500.2 lb+	5
900 lb	899.4 lb	To	900.6 lb	5+2+3 Then 5+1+4

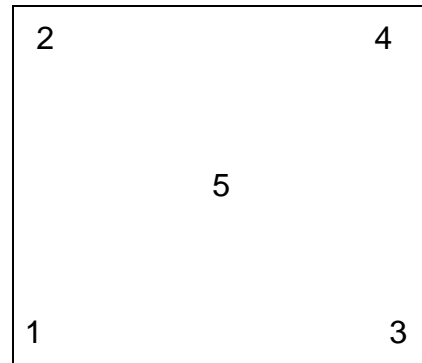

*Use these weights for Corner Test

Weight Positions For Corner Test

APPLICATION OF ADHESIVE/ADHESIVE BACKED ITEMS

1. Use a clean cloth or paper towel to clean the surface with alcohol where the adhesive or adhesive backed item is to be applied.
2. After the alcohol has dried, use another clean dry cloth or paper towel to wipe the surface clean of all residue before the adhesive backed item is applied.
3. Apply the adhesive backed item immediately after the surface has dried. Be careful not to touch either the application surface or the adhesive with the bare hand.
4. Using a clean dry cloth or paper towel, rub out all air bubbles on flat items, such as keypads, labels, serial tags etc., by rubbing back and forth on the surface of the adhesive backed item while pressing firmly.

NOTE: Be sure to press firmly on each corner to insure a good bond.

5. For items that have foam tape, such as standoffs, apply the items square to the surface and hold in place with firm pressure for 5-10 seconds.

NOTE: Most adhesive backed items will not attain full strength until after 24 hours. It is critical that the above procedure be followed to obtain the maximum bonding strength of any adhesive.

PARTS IDENTIFICATION

Final Assembly – 0065-0680-0A

ITEM	QTY	PART NUMBER	DESCRIPTION
1	1	0065-0703-0A	UNIV. BASE ASSY 6560/6570
2	1	0065-0807-0A	6560 COL. AND LATCH ASSY RH
3	1	0065-0808-0A	6560 COL. AND LATCH ASSY LH
4	1	0065-0689-0A	6570 HANDRAIL WELDMENT
5	14	6021-1454	1/4-20 x .750, ZP
6	4	6021-1127	SCW PAN-HEAD, SELF-TAP...6- 32X.5
7	1	0065-0676-08	BACK COVER PLATE, CR SHT 22 GA CQ
8	12	6021-1257	SCW, TRUSS-HEAD THREAD CUTTING, 8-32X.375
9	1	MV1	INDICATOR

NOTES:

1. Wire indicator and load cell cables as shown in schematic. Check to make sure that none of the indicator cables, or load cell cable wires are crossed, or touching where they connect to the trim board to avoid a short circuit. Route cables through available holes.
2. Self-tapping screw (item 6) fastens handrail weldment (item 4) to scale. 2 ea. Self-tapping screws (item 6) are used per columns (items 2 and 3).

PARTS IDENTIFICATION, CONT.

Final Assembly – 0065-0680-0A, Front and Section A-A View

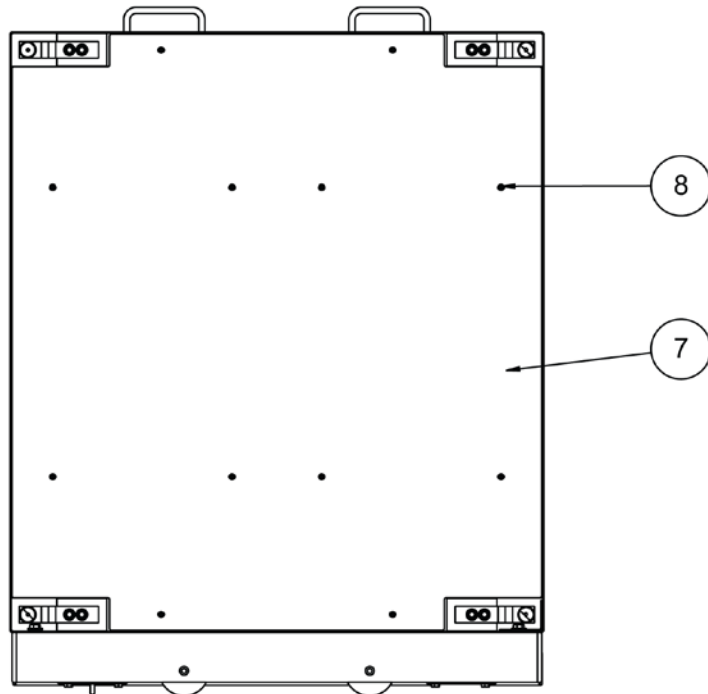
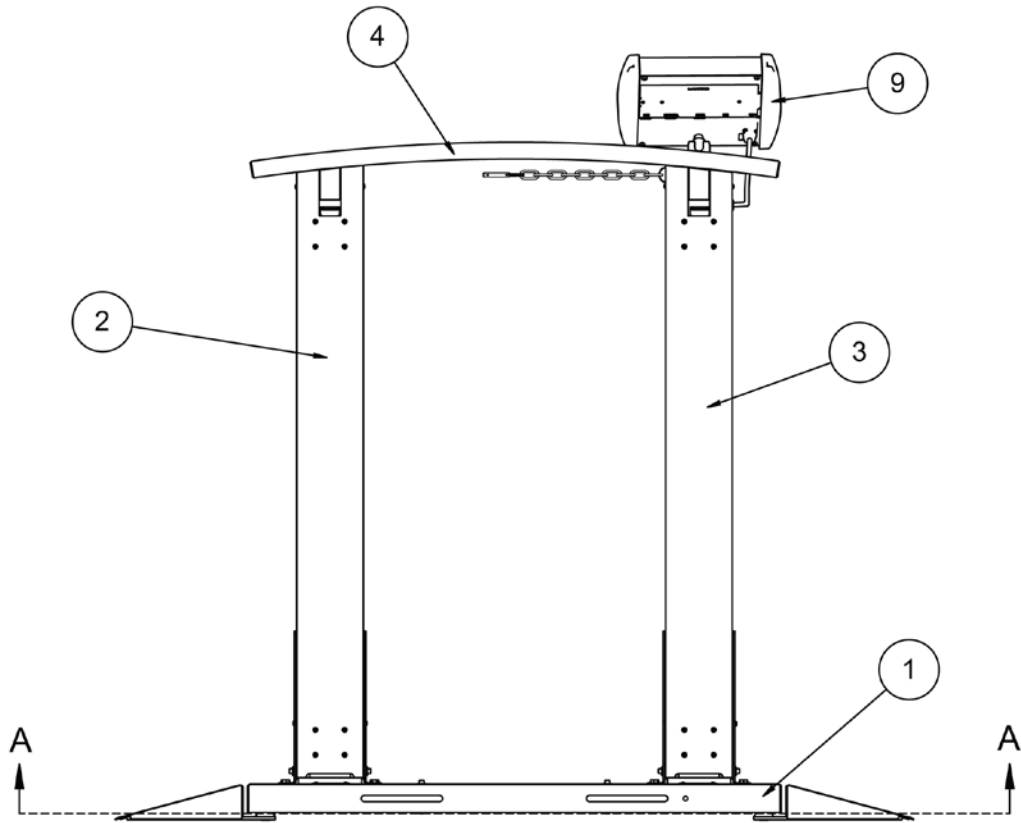

SECTION A-A

PARTS IDENTIFICATION, CONT.

Final Assembly – 0065-0680-0A, Side, Detail B and C View

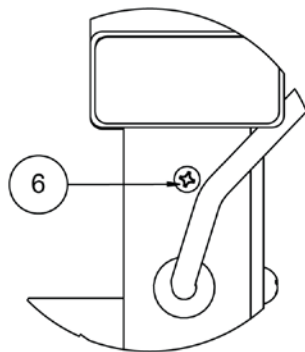
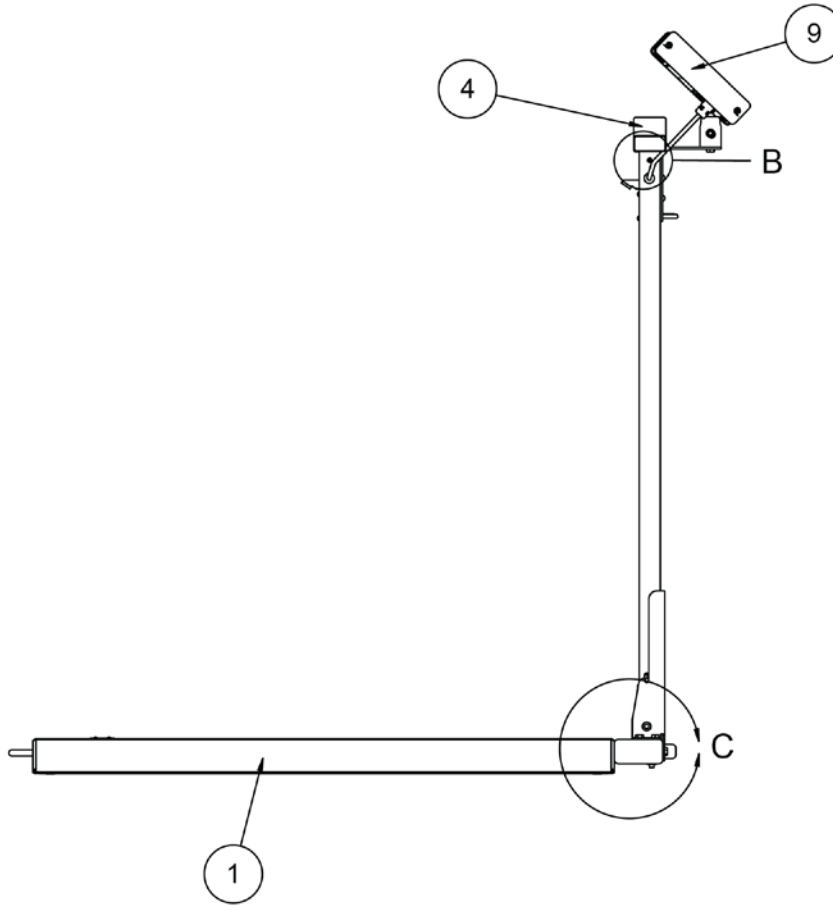

DETAIL B

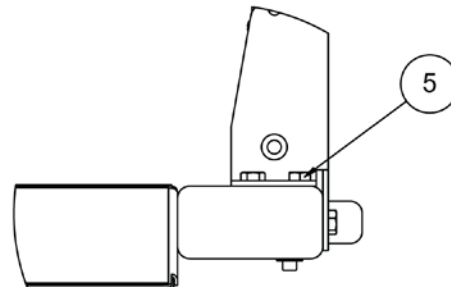

DETAIL C

PARTS IDENTIFICATION, CONT.

Final Assembly – 0065-0680-0A, Wiring Schematic

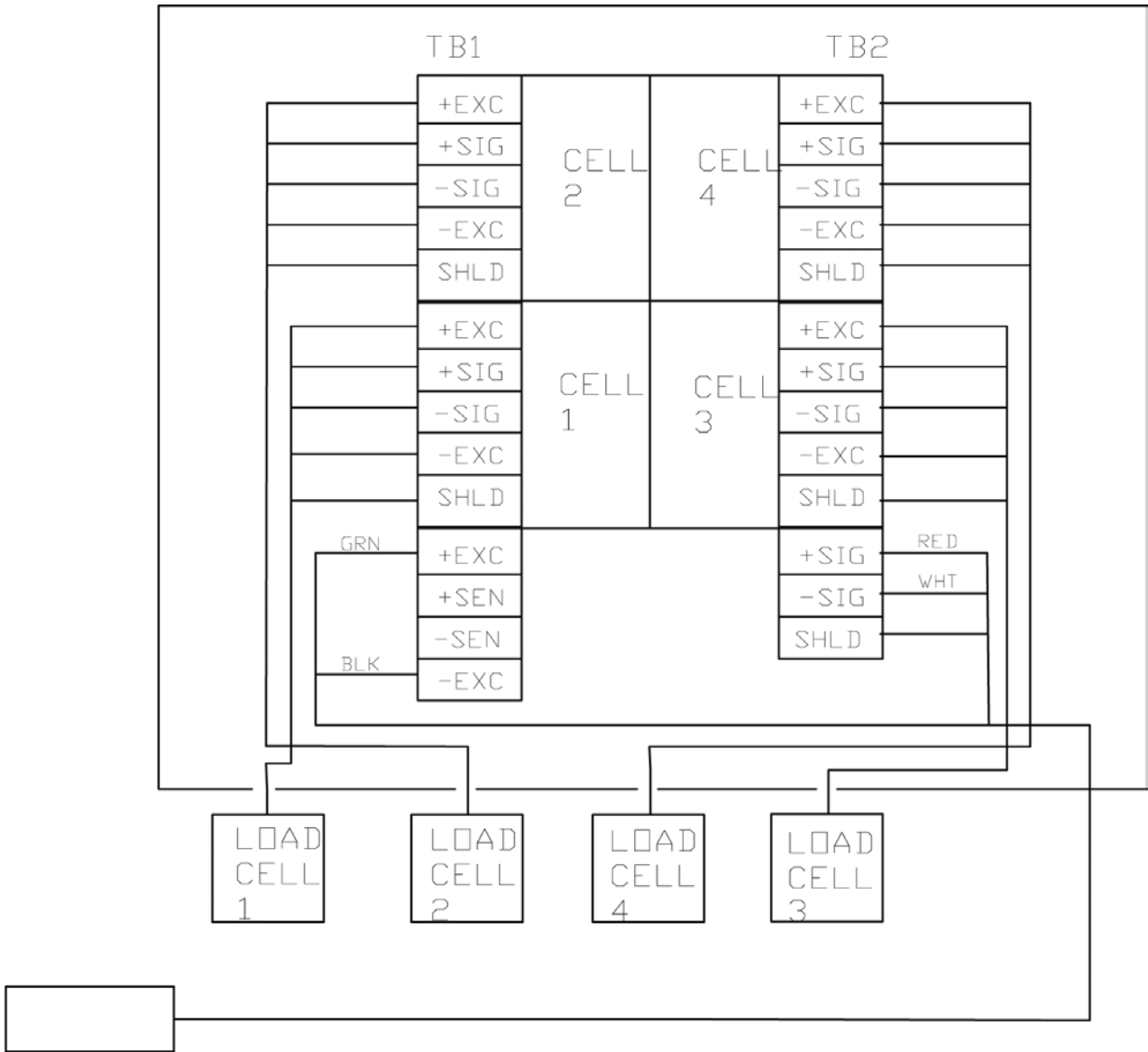

TO WEIGHT
INDICATING
INSTRUMENT

WIRING SCHEMATIC
SEE NOTE 1.

PARTS IDENTIFICATION, CONT.
6560/6570 Universal Base Assembly – 0065-0703-0A

ITEM	QTY	PART NUMBER	DESCRIPTION
1	1	0065-0702-0A	6560/6570 WB WELDMENT
2	2	0065-B539-08	LATCH COVER PLATE, 14 GA, SS 304
3	1	0065-0678-08	HR BTTM BASE/DUAL COLUMN, 3 X 1-1/2 X 3/16 WALL TUBING
4	4	0065-0716-08	LFB-250P
5	4	6540-1624	FOOT, RUBBER, BLACK
6	2	0065-0675-0A	6550 RAMP WELDMENT
7	2	0044-B178-08	HANDLE, 3/8 ROD, 304 SS
8	8	6021-2063	SCW SOCKET-HD CAP-SCREW .375-24
9	4	6021-1045	SCW HEX-HD, MACHINE SCW, 10-32X.5
10	4	6021-1812	SCW FLAT-HEAD.SOCKET CAP., .25-20X.438
11	2	0065-0709-08	1/4" WHEEL SHAFT, SS RD 1/4X12FT 303 ONLY
12	2	574R473	WHEEL, 3'X7/8' 1/4 BORE
13	6	6021-1809	SCW HEX-HEAD, CAP-SCREW, .375-16X.500
14	4	399R40	PUSH NUT, 1/4"
15	8	6680-0180	RIVET POP, BH SS 1/8 DIA x 250-312 GR
16	2	6540-1627	REC. TUBING CAP 1"X3" 8 GA. WALL
17	6	6024-0019	WASHER FLAT 3/8" SS
18	4	0065-0762-08	REINFORCEMENT PLATE, HRPO SHT 12 GA.
19	4	6610-5007	CABLE CLIP 1" x 1"
20	1	3502-C205-0A	TRIM BOARD
21	2	6021-0661	SCW PAN-HEAD, MACHINE-SCW 06-32X.250
22	1	0065-0717-08	6549DS2/6550 - DECK MAT, MAT - SAFTEY TRK RESILIENT BLK
23	2	0065-0718-08	6550/6549DS - RAMP MAT MAT - SAFTEY TRK RESILIENT BLK

PARTS IDENTIFICATION, CONT.

6560/6570 Universal Base Assembly – 0065-0703-0A

NOTES:

1. Center and apply deck mat (item 22) and ramp mat (item 23) on top of deck (item 1) and ramps (item 6) before assembly.
2. HR BTTM base/dual column (item 3) must be attached to deck (item 1) before installation of load cells (item 4).
3. Apply Loctite (6560-1126) to threads of bolt before installation.
4. Ramps can be attached for alignment and positioning of load cells. Ramps will be removed with rubber mounts (item 5) left installed in load cells for calibration and packaging.
5. When installing screws (item 10) into rubber mounts (item 5) for alignment purposes, be careful not to overtighten as this may shear rubber mount.
6. Ensure that screws (item 10) are set aside for individual packaging.
7. Ensure all wiring is routed to trim board through available holes in stiffeners.
8. Tighten load cell bolts (item 8) to 35 ft-lbs.
9. Tighten screws (item 21) until snug and PCB is held firmly in place. Do not overtighten for risk of crushing PCB.

PARTS IDENTIFICATION, CONT.

6560/6570 Universal Base Assembly – 0065-0703-0A

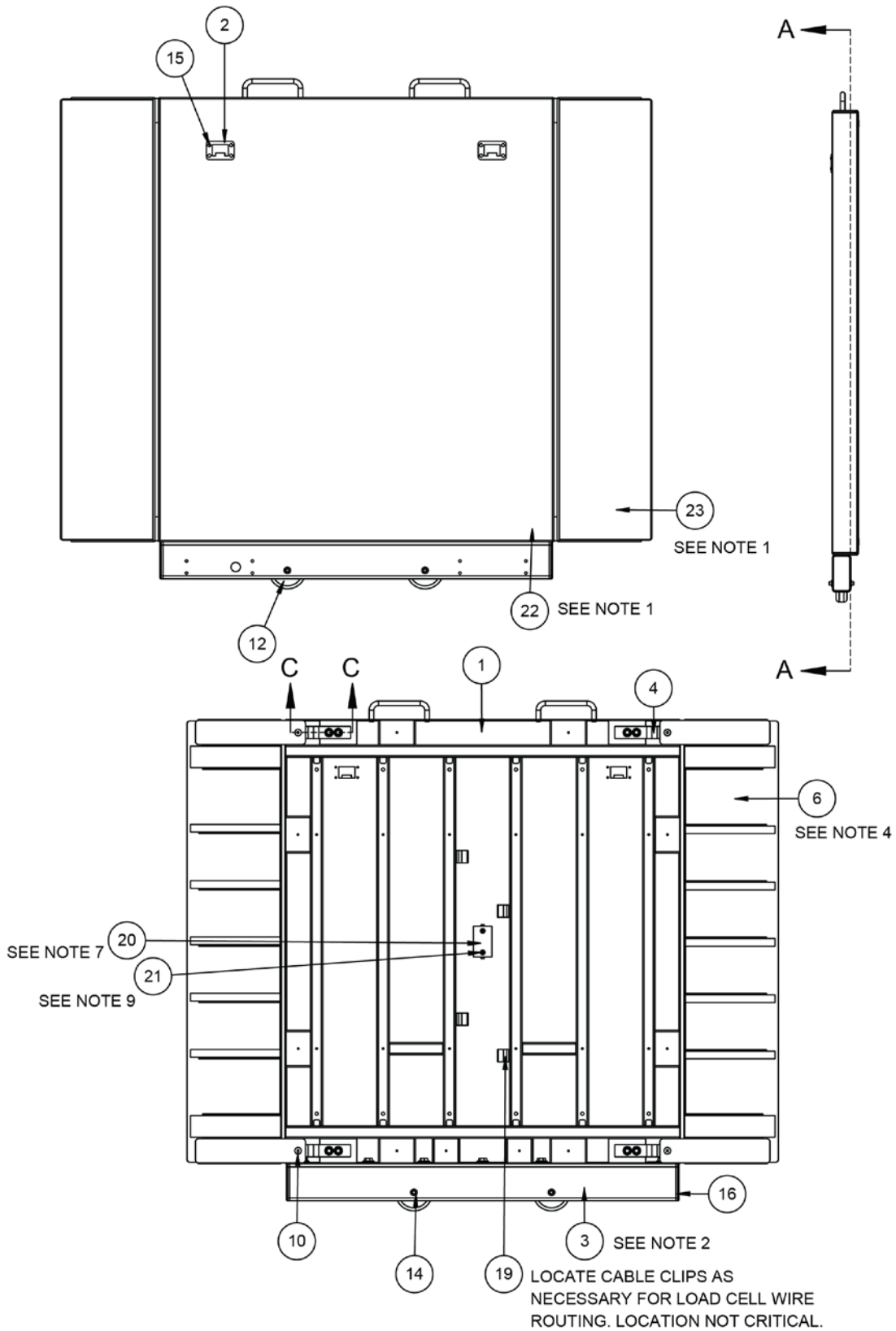

PARTS IDENTIFICATION, CONT.
6560/6570 Universal Base Assembly – 0065-0703-0A
Section A-A, Detail B, and Section C-C View

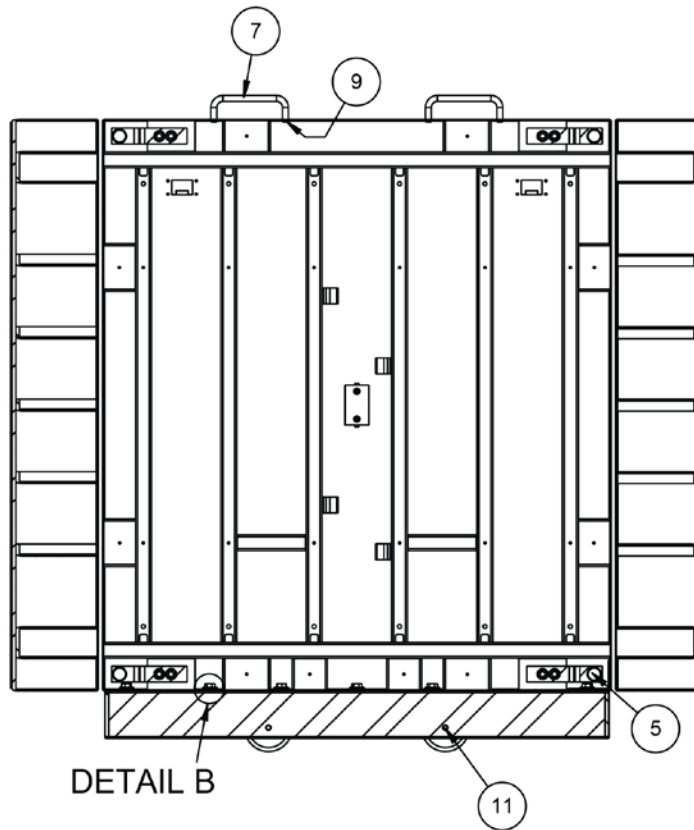

DETAIL B

SECTION A-A

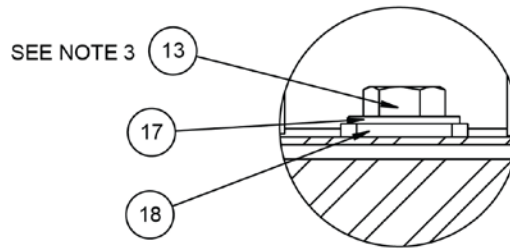

DETAIL B

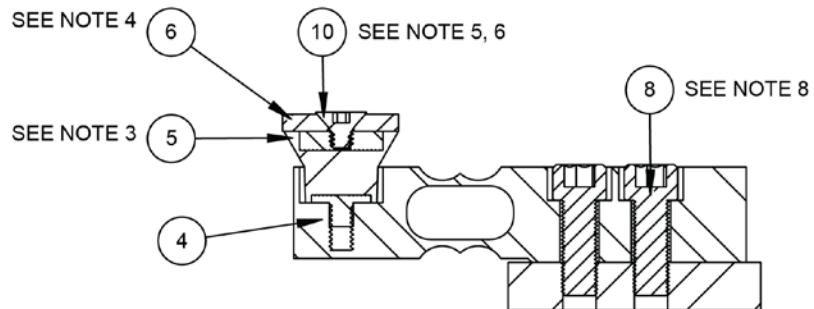

SECTION C-C

PARTS IDENTIFICATION, CONT.
LH Column and Latch Assembly – 0065-0808-0A

ITEM	QTY	PART NUMBER	DESCRIPTION
1	1	0065-0786-0A	COLUMN WELDMENT LH - 6560
2	1	0065-0758-0A	COL. FACE SPOT WELD ASSY
3	1	0065-0697-08	6549DS COLUMN SWIVEL BASE, SS SHT 12 GA.X48X96
4	1	0065-B342-08	PIN - COLUMN PIVOT, SS RD 1/4 X 12 FT
5	2	399R40	PUSH NUT, 1/4"
6	2	0065-B374-08	LATCH SPACER, POLYETHELENE .060 X 48 X 96
7	1	0065-C347-08	GUIDE – LATCH, SS SHT 14 GA.
8	1	0065-B351-08	LINK BAR, HRPO SHT 14 GA. X 48 X 96
9	1	0031-B014-08	SPACER, BRS TBG 1/4 OD X .025 WALL
10	1	0065-B442-08	LATCH SHAFT, SS HEX 3/8 X 12 FT
11	1	0065-C443-08	GUIDE, LATCH LOWER, SS SHT 14 GA.
12	1	6022-0027	SPRING, EXT. 1 7/8 LONG
13	1	6680-0038	WASHER FLAT #10 TYPE
14	1	6021-1020	SCW ROUND HEAD #10-32 X 0.375
15	1	0065-B373-0A	LATCH BLOCK, LOWER
16	1	0065-0798-0A	LATCH WELDMENT 6570
17	1	0065-0696-08	TRANSITION PLATE 6560, HRPO SHT 10 GA. X 48 X 96
18	1	6021-1454	1/4-20 x .750, ZP
19	1	6024-1066	WASHER FLAT 1/4 X 1 X 1/16 TK
20	1	6680-0250	SPACER .26 ID X .5 OD X .187
21	1	391RV204	NUT 1/4-20 ELASTIC STOP Z/P
22	3	6021-1006	SCW SELF-TAP... 10-32X.500 S. S.
23	1	6021-0950	MACHINE SCW 10-32X1.5
24	1	6540-1053	ENCLOSURE KNOB 1.25 DIA, 10-32
25	2	8555-C508-08	MOUNT

PARTS IDENTIFICATION, CONT.
LH Column and Latch Assembly – 0065-0808-0A

ITEM	QTY	PART NUMBER	DESCRIPTION
26	1	6680-1043	GROMMET 1/4 ID X 5/8 OD 1/8 TK
27	1	0065-B403-0A	CABLE, INDICATOR
28	1	6013-0295	NUT #10-32 HEX Z/P
29	8	6021-0665	MACHINE-SCW 06-32X.375
30	1	6028-0093	PIN HITCH
31	1	6028-0094	SPLIT RING
32	1	6680-1014	CHAIN

NOTES:

1. Apply Loctite (6560-1061) to threads of bolt.
2. Remove paint from parts as necessary for assembly.

PARTS IDENTIFICATION, CONT.

LH Column and Latch Assembly – 0065-0808-0A

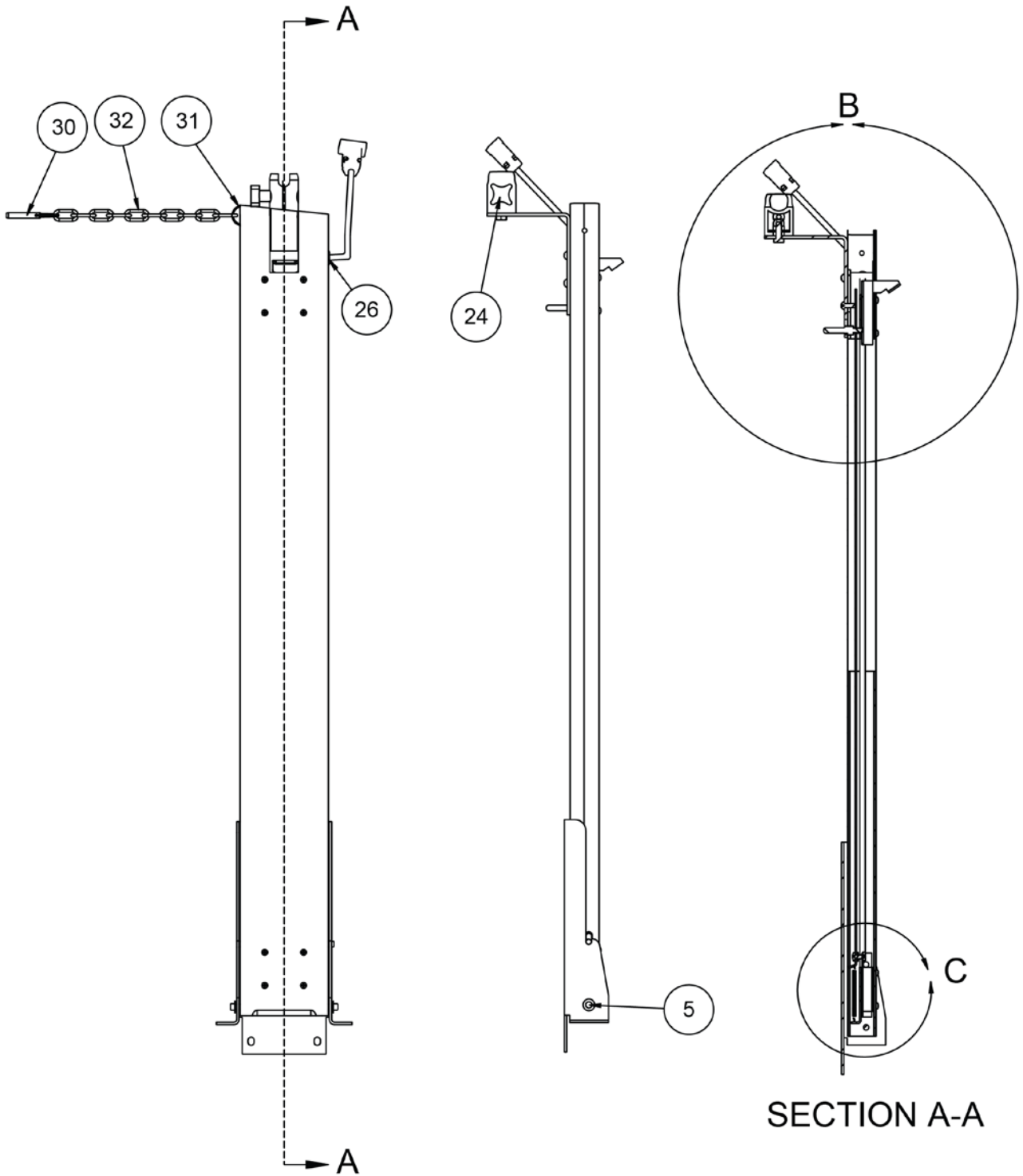

PARTS IDENTIFICATION, CONT.

LH Column and Latch Assembly – 0065-0808-0A, Detail B and C

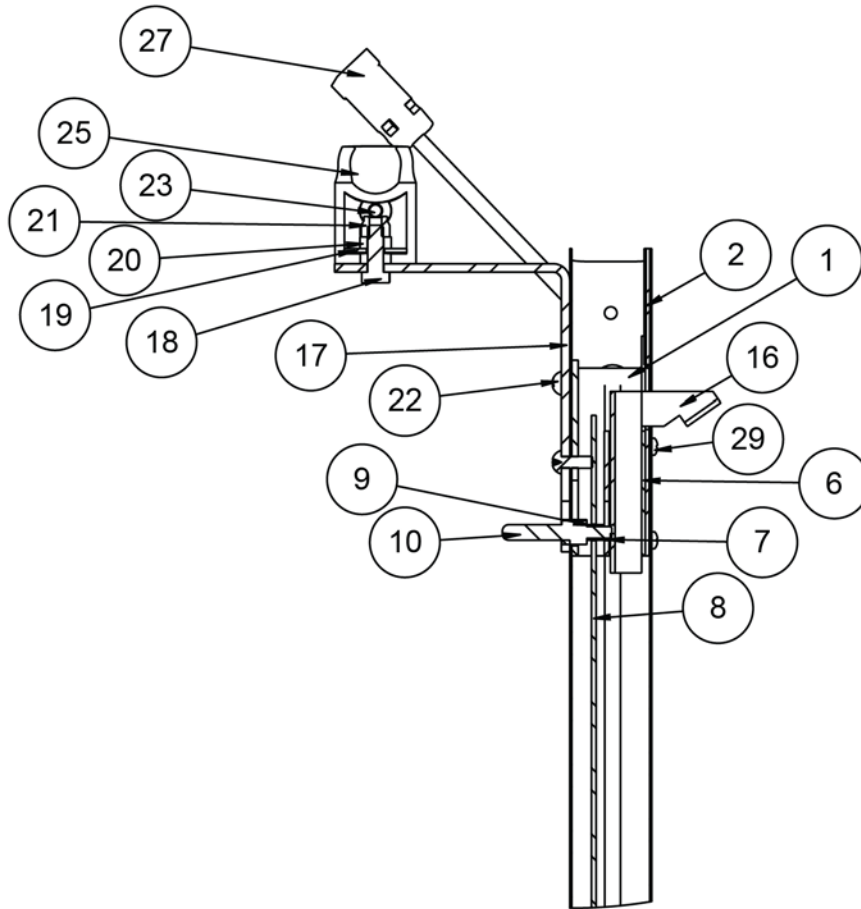

DETAIL B

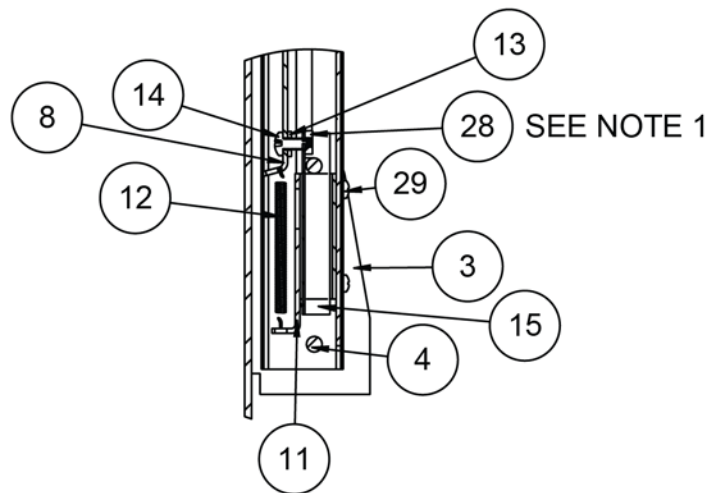

DETAIL C

PARTS IDENTIFICATION, CONT.
RH Column and Latch Assembly – 0065-0807-0A

ITEM	QTY	PART NUMBER	DESCRIPTION
1	1	0065-0785-0A	COLUMN WELDMENT RH - 6560
2	1	0065-0758-0A	COL. FACE SPOT WELD ASSY
3	1	0065-C347-08	GUIDE – LATCH, SS SHT 14 GA.
4	2	0065-B374-08	LATCH SPACER, POLYETHELENE .060 X 48 X 96
5	1	0065-C443-08	GUIDE, LATCH LOWER, SS SHT 14 GA.
6	1	0031-B014-08	SPACER, BRS TBG 1/4 OD X .025 WALL
7	1	0065-B442-08	LATCH SHAFT, SS HEX 3/8 X 12 FT
8	1	0065-0697-08	6549DS COLUMN SWIVEL BASE, SS SHT 12 GA.X48X96
9	1	0065-B373-0A	LATCH BLOCK, LOWER
10	1	0065-B351-08	LINK BAR, HRPO SHT 14 GA. X 48 X 96
11	1	6022-0027	SPRING, EXT. 1 7/8 LONG
12	1	6680-0038	WASHER FLAT #10 TYPE
13	1	6021-1020	SCW ROUND HEAD #10-32 X 0.375
14	1	0065-B342-08	PIN - COLUMN PIVOT, SS RD 1/4 X 12 FT
15	2	399R40	PUSH NUT, 1/4"
16	1	0065-0798-0A	LATCH WELDMENT 6570
17	3	6021-1006	SCW 10-32X.500 S. S.
18	1	6013-0295	NUT #10-32 HEX Z/P
19	8	6021-0665	MACHINE-SCW 06-32X.375
20	1	0065-0695-08	LATCH COVER 6560, HRPO SHT 12 GA. X 48 X 96

NOTES:

1. Apply Loctite (6560-1061) to threads of bolt.
2. Remove paint from parts as necessary for assembly.

PARTS IDENTIFICATION, CONT.

RH Column and Latch Assembly – 0065-0807-0A

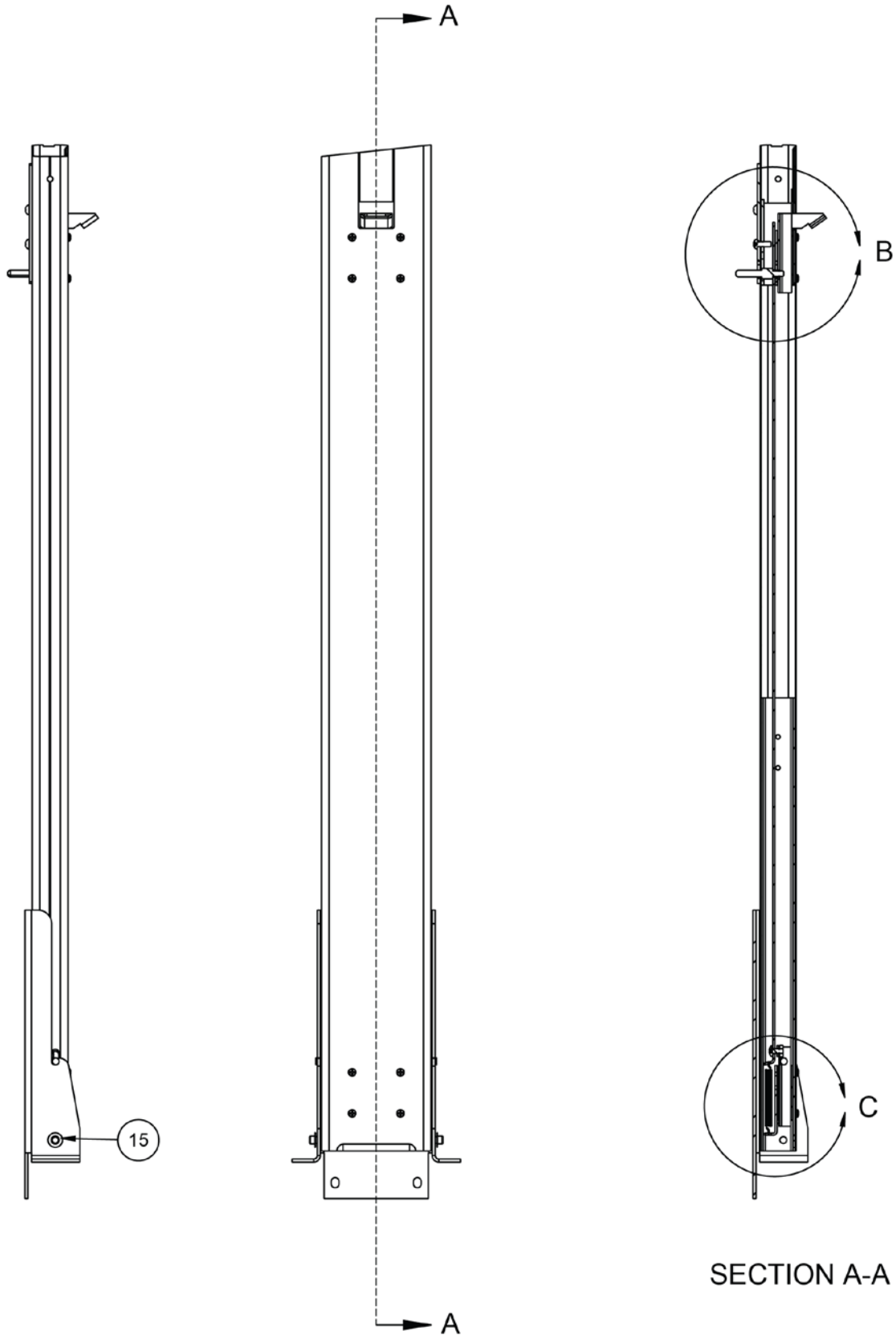

PARTS IDENTIFICATION, CONT.

RH Column and Latch Assembly – 0065-0807-0A, Detail B and C

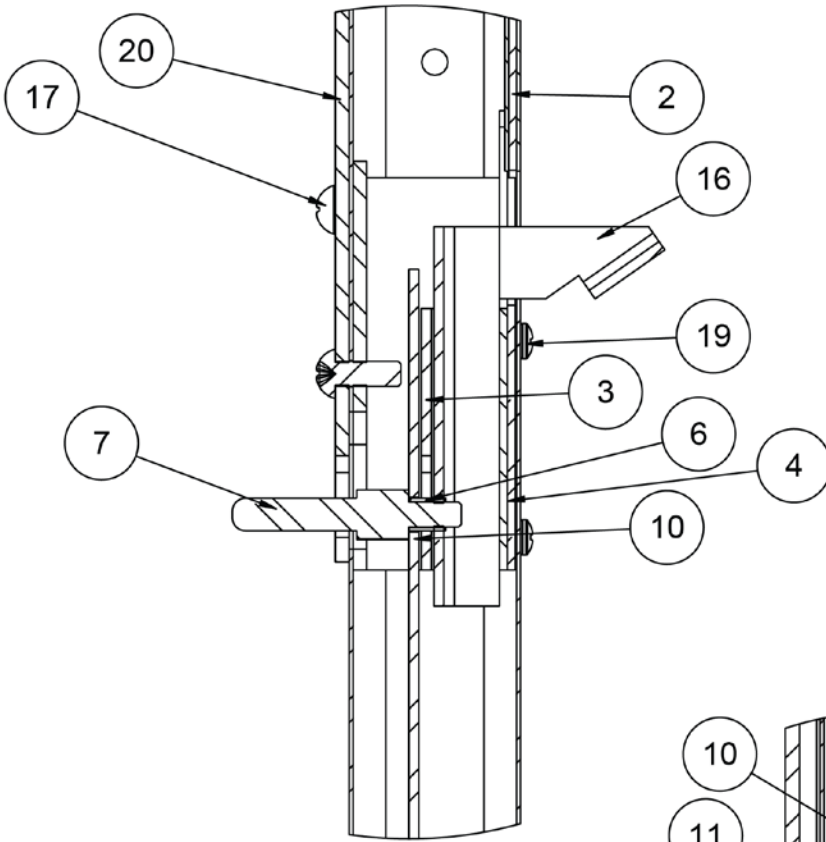

DETAIL B

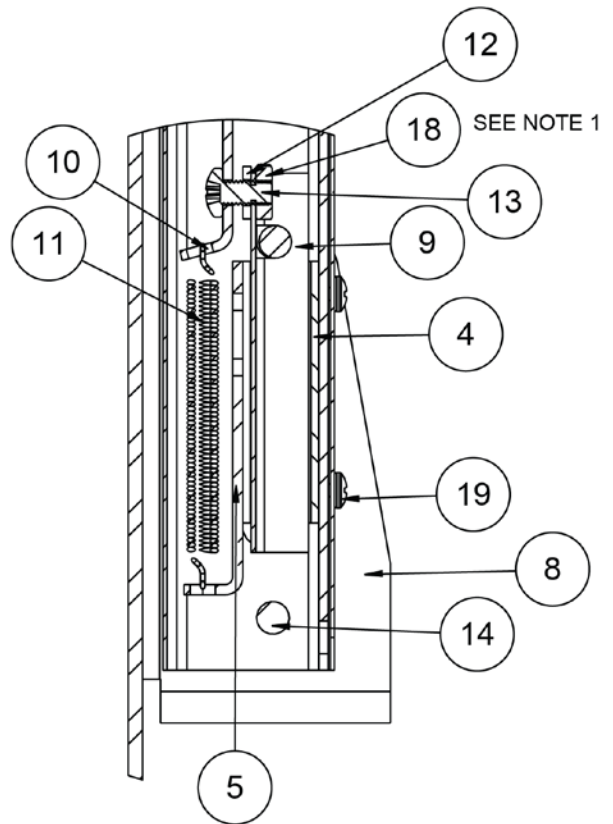

DETAIL C

STATEMENT OF LIMITED WARRANTY

Detecto Scale warrants its equipment to be free from defects in material and workmanship as follows: Detecto warrants to the original purchaser only that it will repair or replace any part of equipment which is defective in material or workmanship for a period of **two (2) years from date of shipment**. Detecto shall be the sole judge of what constitutes a defect.

During the **first ninety (90) days** Detecto may choose to replace the product at no charge to the buyer upon inspection of the returned item.

After the first ninety (90) days, upon inspection of the returned item, Detecto will repair or replace it with a remanufactured product. The customer is responsible for paying for the freight both ways.

This warranty does not apply to peripheral equipment not manufactured by Detecto; this equipment will be covered by certain manufacturer's warranty only.

This warranty does not include replacement of expendable or consumable parts. This does not apply to any item which has deteriorated or damaged due to wear, accident, misuse, abuse, improper line voltage, overloading, theft, lightning, fire, water or acts of God, or due to extended storage or exposure while in purchaser's possession. This warranty does not apply to maintenance service. Purchased parts will have a ninety (90) day repair or replacement warranty only.

Detecto may require the product to be returned to the factory; item(s) must be properly packed and shipping charges prepaid. A return authorization number must be obtained for all returns and marked on the outside of all returned packages. Detecto accepts no responsibility for items lost or damaged in transit.

Conditions Which Void Limited Warranty

This warranty shall not apply to equipment which:

- A.) Has been tampered with, defaced, mishandled or has had repairs and modifications not authorized by Detecto.
- B.) Has had serial number altered, defaced, or removed.
- C.) Has not been properly grounded according to Detecto's recommended procedure.

Freight Carrier Damage

Claims for equipment damaged in transit must be referred to the freight carrier in accordance with freight carrier regulations.

This warranty sets forth the extent of our liability for breach of any warranty or deficiency in connection with the sale or use of the product. Detecto will not be liable for consequential damages of any nature, including but not limited to, loss of profit, delays or expenses, whether based on tort or contract. Detecto reserves the right to incorporate improvements in material and design without notice and is not obligated to incorporate improvements in equipment previously manufactured.

The foregoing is in lieu of all other warranties, express or implied including any warranty that extends beyond the description of the product including any warranty of merchantability or fitness for a particular purpose. This warranty covers only those Detecto products installed in the forty-eight (48) contiguous continental United States.



Ph. (800) 641-2008
E-mail: detecto@cardet.com
203 E. Daugherty
Webb City, MO 64870

08/27/2014
Printed in USA
D268-WARRANTY-DET-A



Printed in USA

0065-0729-0M Rev A 09/18



Cardinal Scale Manufacturing Co.
203 E. Daugherty, Webb City, MO 64870 USA
Ph: 417-673-4631 or 1-800-641-2008
Fax: 417-673-2153

Technical Support: 1-866-254-8261
E-mail: tech@cardet.com